

# THE POWER OF

# REDARC®

## Multi-stage 12 V Input Current Limited In-vehicle Battery Charger

### BCDC1212T

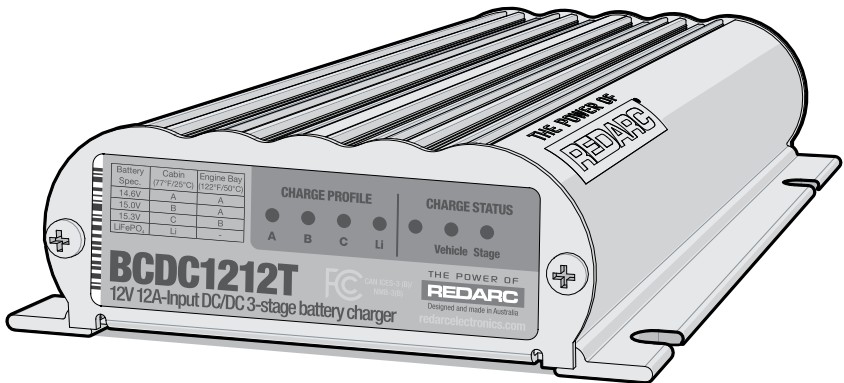

# THE BCDC1212T

---

The BCDC1212T In-vehicle Battery Charger features technology designed to charge your auxiliary batteries to 100%, regardless of their type or size.

The In-vehicle Battery Charger is suitable for all common types of automotive lead acid batteries and LiFePO<sub>4</sub> lithium type batteries.

## WARNING AND SAFETY INSTRUCTIONS

---

**SAVE THESE INSTRUCTIONS - THIS MANUAL CONTAINS IMPORTANT SAFETY INSTRUCTIONS FOR THE BCDC1212T BATTERY CHARGER.**

**DO NOT OPERATE THE BATTERY CHARGER UNLESS YOU HAVE READ AND UNDERSTOOD THIS MANUAL AND THE CHARGER IS INSTALLED AS PER THESE INSTALLATION INSTRUCTIONS. REDARC RECOMMENDS THAT THE CHARGER BE INSTALLED BY A SUITABLY QUALIFIED PERSON.**

### WARNING

**RISK OF EXPLOSIVE GASES:**

**WORKING IN VICINITY OF A LEAD-ACID BATTERY IS DANGEROUS. BATTERIES GENERATE EXPLOSIVE GASES DURING NORMAL OPERATION. FOR THIS REASON, IT IS OF UTMOST IMPORTANCE THAT YOU FOLLOW THE INSTRUCTIONS WHEN INSTALLING AND USING THE CHARGER.**

### CAUTION

1. The Battery Charger should not be used by persons (including children) with reduced physical, sensory or mental capabilities, or lack of experience and knowledge, unless they are supervised or have been instructed on how to use the appliance by a person responsible for their safety. Children should be supervised to ensure that they do not play with the Battery Charger.
2. Do NOT alter or disassemble the Battery Charger under any circumstances. All faulty units must be returned to REDARC for repair. Incorrect handling or reassembly may result in a risk of electric shock or fire and may void the unit warranty.
3. Only use the Battery Charger for charging Standard Automotive Lead Acid, Calcium Content, Gel, AGM, SLI (Starting Lighting Ignition), Deep Cycle or Lithium Iron Phosphate (LiFePO<sub>4</sub>) type 12 V batteries.
4. Check the manufacturer's data for your battery and ensure that the 'Maximum' voltage of the profile you select does not exceed the manufacturer's recommended maximum charging voltage. If the 'Maximum' voltage is too high for your battery type, please select another charging profile.

5. Check the manufacturer's data for your battery and ensure that the 'Continuous Current Rating' of the charger does not exceed the manufacturer's recommended maximum charging current.
6. When using the Battery Charger to charge a Lithium Iron Phosphate (LiFePO<sub>4</sub>) battery, only batteries that feature an inbuilt battery management system featuring inbuilt under and over voltage protection and cell balancing are suitable.
7. The Battery Charger is not intended to supply power to a low voltage electrical system other than to charge a battery.
8. Cable and fuse sizes are specified by various codes and standards which depend on the type of vehicle the Battery Charger is installed into. Selecting the wrong cable or fuse size could result in harm to the installer or user and/or damage to the Battery Charger or other equipment installed in the system. The installer is responsible for ensuring that the correct cable and fuse sizes are used when installing this Battery Charger.
9. NEVER smoke or allow a spark or flame in the vicinity of battery or engine. This may cause the battery to explode.
10. In applications where the BCDC1212T draws power through the vehicle's and trailer's towing harnesses and connectors, the harnesses wiring gauge, connectors and fuse current ratings and fuse type should be checked by a suitably qualified person to ensure that it is adequately rated for safe and reliable operation and that the vehicle's fuse is appropriately rated and located to protect the wiring in the event of a fault, including short circuits.

### PERSONAL SAFETY PRECAUTIONS

11. To assist with the safe operation and use of the Battery Charger when connected to the battery:
  - Wear complete eye protection and clothing protection. Avoid touching eyes while working near a battery.
  - If battery acid contacts your skin or clothing, remove the affected clothing and wash the affected area of your skin immediately with soap and water. If battery acid enters your eye, immediately flood the eye with running cold water for at least 10 minutes and seek medical assistance immediately.

# CONTENTS

<b>THE BCDC1212T</b>	<b>2</b>	<b>2</b>	<b>INSTALLATION</b>	<b>8</b>	
<b>WARNING AND SAFETY INSTRUCTIONS</b>	<b>2</b>	<b>2.1</b>	<b>Install Location</b>	<b>8</b>	
<b>SPECIFICATIONS</b>	<b>3</b>	<b>2.2</b>	<b>Charge Profile Selection (ORANGE Wire)</b>	<b>9</b>	
<b>1</b>	<b>PRODUCT FUNCTION</b>	<b>4</b>	<b>2.3</b>	<b>Input Trigger Settings (BLUE Wire)</b>	<b>10</b>
<b>1.1</b>	<b>Display Panel</b>	<b>4</b>	<b>2.4</b>	<b>Cable sizing</b>	<b>10</b>
<b>1.2</b>	<b>Charge Profile LEDs</b>	<b>4</b>	<b>2.5</b>	<b>Wiring</b>	<b>11</b>
<b>1.3</b>	<b>Charge Status LEDs</b>	<b>5</b>	<b>2.6</b>	<b>Fusing</b>	<b>11</b>
1.3.1	Vehicle LED	5	<b>2.7</b>	<b>Typical Setup</b>	<b>12</b>
1.3.2	Stage LED	5	<b>3</b>	<b>TROUBLESHOOTING</b>	<b>13</b>
1.3.3	Optional External LED	6	<b>4</b>	<b>CHECKING THE PRODUCT SERIAL NUMBER</b>	<b>13</b>
1.3.4	Charging Process	6	<b>5</b>	<b>FCC DECLARATION</b>	<b>14</b>
<b>1.4</b>	<b>Turn On/Off Thresholds</b>	<b>7</b>	<b>6</b>	<b>FREQUENTLY ASKED QUESTIONS</b>	<b>14</b>
<b>1.5</b>	<b>Error Codes</b>	<b>7</b>	<b>7</b>	<b>TWO YEAR PRODUCT WARRANTY — NORTH AMERICA</b>	<b>15</b>
<b>1.6</b>	<b>Battery Test Mode</b>	<b>8</b>			

## SPECIFICATIONS

Part Number	BCDC1212T		
Continuous Input Current Rating	12 A		
Fuse Rating (Input / Output)	15 A to 23 A / 30 A (Not supplied)		
Vehicle Input Voltage Range*	9 to 32 V		
Nominal System Voltage	12 V	24 V	
Max. Rated Output Current	11 A	20 A	
Nominal Output Power	147 W	294 W	
Output Battery Type	Standard Lead Acid, Calcium content, Gel, AGM or LiFePO <sub>4</sub> type only		

Charging Profile	A	B	C	Li
– Maximum Voltage* (refer to section 1.2)	14.6 V	15.0 V	15.3 V	14.5 V
– Float Voltage*	13.3 V			13.6 V
No Load Current	<100 mA			
Standby Current	<8 mA			
Minimum O/P Battery Volts	0.1 V			
Operating Temperature	5°F to 175°F / –15°C to 80°C			
Charging Temperature	A, B & C – Output Batt. > 10.5 V	5°F to +176°F / –15°C to +80°C		
	A, B & C – Output Batt. < 10.5 V	32°F to +176°F / 0°C to +80°C		
	LiFePO <sub>4</sub> Batteries	32°F to +176°F / 0°C to +80°C		
Weight	30 oz / 850 g			
Dimensions	6.5" × 4.7" × 1.5" / 165 × 120 × 37 mm			
Warranty	2 years			
EMC Compliance	RCM, FCC, ICES			

\* Voltages Specified are ±100 mV

# 1 PRODUCT FUNCTION

The BCDC1212T is specifically designed for, but not limited to, applications where the input current required to charge a trailer mounted auxiliary battery is drawn through the vehicle's towing harnesses and connectors. It limits the input current drawn to 12 A which provides for safe and reliable operation when using towing harnesses, fuses and connectors that are suitably rated without the need to install additional cables and connectors between the start battery / alternator and the BCDC1212T / auxiliary battery.

The BCDC1212T is a three-stage, 12 V DC-DC battery charger that operates from an alternator input of 12 V or 24 V. The input voltage to the BCDC1212T can be above, below or equal to the output voltage making it ideal for charging an auxiliary 12 V battery where the distance from the start battery or alternator may cause a significant voltage drop. When connected to a 12 V alternator the BCDC1212T will typically provide peak boost currents of 11 A, and 20 A when connected to a 24 V alternator (the peak boost current however also depends on alternator voltage and input cable voltage drop).

The BCDC1212T isolates the start battery from the auxiliary battery, to avoid over-discharging the start battery.

## 1.1 Display Panel

The front panel features 7 LEDs to display the charge profile and charge status.

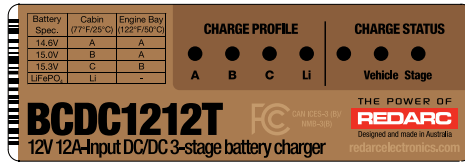

FIGURE 1.1.1: The BCDC1212T Front Panel

## 1.2 Charge Profile LEDs

The In-vehicle Battery Charger features 4 different charging profiles designed to suit your battery's charging requirements. It is recommended to refer to the charging specifications stated by the battery manufacturer and the installation temperature chart below (Figure 1.2.1) before selecting the profile for your installation.

The selected Charge Profile LED will be on solid when the unit is ON and charging. A flashing profile LED indicates that the unit is in standby mode and NOT charging.

### **⚠ CAUTION**

Check the manufacturer's data for your battery and ensure that the 'Maximum' voltage of the profile you select does not exceed the manufacturer's recommended maximum charging voltage. If the 'Maximum' voltage is too high for your battery type, please select another charging profile.

# 1 PRODUCT FUNCTION

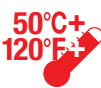
MAXIMUM BATTERY VOLTAGE SPECIFICATION	AUXILIARY BATTERY LOCATION	
	CABIN INSTALL	ENGINE BAY INSTALL
		
14.6	A	A
15.0	B	A
15.3	C	B
14.5 (LiFePO <sub>4</sub> )	Li	Not Recommended

**FIGURE 1.2.1:** Charge Profile Selection

## 1.3 Charge Status LEDs

The Charge Status LEDs indicate to the user which inputs are available and what stage of the charge process the unit is currently in.



### 1.3.1 Vehicle LED

The Vehicle LED will be ON when the input is available and in use and OFF when the input is not available or not in use.

### 1.3.2 Stage LED

The Stage LED indicates the charge profile stage. With any profile selected the charger will output a 3-Stage charging profile consisting of Boost, Absorption and Float Stages.

Figure 1.3.2.1 outlines the LED sequences which indicate these stages and figure 1.3.4.1 explains the Charging Process.

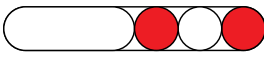
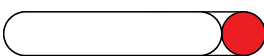
LED SEQUENCE	PROFILE STAGE (LITHIUM)
Continuous 	OFF / No Output
Continuous 	Boost (Constant Current)
2 seconds 	Absorption (Constant Voltage)
2 seconds 	Float

**FIGURE 1.3.2.1:** Stage LED Sequences

## 1.3.3 Optional External LED

An option external LED (see Figures 2.7.1 and 2.7.2) can be used to provide charge status and error feedback away from the BCDC unit and is voltage limited to 9 V and current limited to 6 mA. A serial resistor and LED should be selected to these specifications. A basic 3 V LED can be wired as shown.

If used, this external LED is either OFF (BCDC not charging), ON (BCDC charging) or FLASHING (see error codes in Section 1.5 Error Codes). A “12 V” LED (3 V with integrated resistor) will not operate correctly if installed.

## 1.3.4 Charging Process

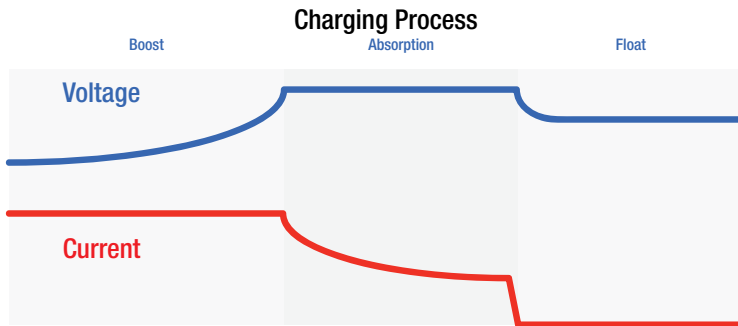

FIGURE 1.3.4.1: Charging Process

When the Charger is turned on, it will move into the Boost stage. The Boost stage maintains a constant current until the battery voltage reaches its Absorption Voltage. The current in Boost stage may vary during operation in order to maintain safe operating temperature, or to limit the difference between input and output voltages.

The Charger will then move to Absorption stage which maintains a constant voltage level for a predetermined period of time or until the current being drawn by the output battery drops to less than 4 A for 30 seconds; after which the Charger will enter Float stage.

Float stage maintains 13.3 V (13.6 V for LiFePO<sub>4</sub>) on the output battery, keeping the battery topped up. This counteracts the battery's self discharging or loads applied to the battery. When the battery loses charge, the Charger will move back into the Boost stage.

### **⚠ CAUTION**

When using the Battery Charger to charge a Lithium Iron Phosphate battery, only batteries that feature an inbuilt battery management system featuring inbuilt under and over voltage protection and cell balancing are suitable.

# 1 PRODUCT FUNCTION

## 1.4 Turn On/Off Thresholds

	Input	12 V Vehicle Input		24 V Vehicle Input	
	Input Trigger Settings	Standard	Low Voltage	Standard	Low Voltage
Input Open Circuit Low voltage conditions **	Turn ON above	12.9 V	12.0 V	25.8 V	24.0V
	Turn OFF below	12.7 V	11.9 V	25.4 V	23.8 V
Input Loaded Low voltage conditions***	Turn OFF instantly below	8.0 V		16.0 V	
	Turn OFF after 20 s below	9.0 V		18.0 V	
Input Over voltage shutdown	Turn ON below	15.5 V		32 V	
	Turn OFF instantly above	16.0 V		32.5 V	
	Turn OFF after 20 s above	15.6 V		32.1 V	
Output Under voltage shutdown **	Shutdown if Output Battery < 0.1 V				

\*\*Tested every 100 Seconds | \*\*\* Constantly tested

There is a maximum 20 second delay before the charger will produce an output any time a source is introduced into the system, this allows the unit to provide optimum input sharing and effective battery isolation.

## 1.5 Error Codes

In the event of a fault with the unit installation or either battery, ALL the LEDs on the unit will flash to indicate the fault type. Flashing sequences are described in the table below.

LED STATE	DESCRIPTION
1 flash (1 flash followed by 3.5 second off)	Internal Hardware Fault
2 flash (2 flash followed by 3.5 second off)	Unit under temp fault
3 flash (3 flash followed by 3.5 second off)	Unit over temp fault
4 flash (4 flash followed by 3.5 second off)	Output Battery Fault (Volts too high)
5 flash (5 flash followed by 3.5 second off)	Input under voltage (Battery)
6 flash (6 flash followed by 3.5 second off)	Input over voltage (Battery)

# 1 PRODUCT FUNCTION

---

## 1.6 Battery Test Mode

The unit features a battery test mode which occurs every 100 seconds. The test mode is designed to both test that the input conditions are still met and check for the presence of a battery on the output of the unit. This feature is designed to protect the vehicle battery from over discharge and protect the vehicle and wiring in the event of damage to the output connection. During low output current situations (when in Float mode for example) this battery test may take up to 60 seconds to complete.

# 2 INSTALLATION

---

## 2.1 Install Location

The charger is suitable for mounting in the trailer nose cone, cabin of the vehicle, along a chassis rail or in the engine bay (ensure the unit does not become covered by a build up of mud or other material and BCDC and wiring is not exposed to mechanical damage). If mounting in an engine bay, locate the unit away from high temperature areas for maximum performance. Choose locations such as on the inner guard, behind a headlight or behind the grille to one side of the radiator. The unit will operate optimally below 130°F / 55°C with good airflow. At higher temperatures the unit will de-rate output current up to 176°F / 80°C at which point the unit will turn OFF.

It is important to ensure the charger is mounted as close as possible to the battery being charged (auxiliary battery). Certain batteries are better suited to each of these types of installations so it is important to select the correct battery type. For more information consult your battery manufacturer's specifications.

**NOTE:** Lithium type (LiFePO<sub>4</sub>) batteries may not be suitable for engine bay installations. Refer to Figure 1.2.1 for selecting the best Charge Profile for your installation.

The charger operates in any orientation (but it is recommended that the front decal be visible). Mount using the 4 mounting tabs provided on the heatsink (refer Figure 2.1.1) with ¼" (or M6) screws being suitable gauge. Length is to be chosen as appropriate for specific installation.

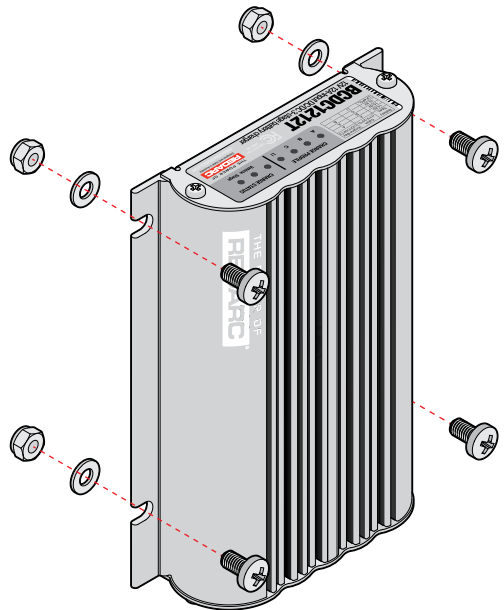

**FIGURE 2.1.1:** Mounting the Charger



### 2.2 Charge Profile Selection (ORANGE Wire)

The ORANGE wire is used to select the Maximum output voltage. This is achieved by connecting in the following way:

- To select **Profile A** leave the ORANGE wire disconnected. This will set the Maximum voltage to 14.6 V.
- To select **Profile B** connect the ORANGE wire to Common Ground. This will set the Maximum voltage to 15.0 V.
- To select **Profile C** connect the ORANGE wire to the RED wire (Input source positive). This will set the Maximum voltage to 15.3 V.
- To select the **Li Profile** connect the ORANGE wire to the GREEN wire (LED output). This will set the charger to Lithium mode.

#### **⚠ CAUTION**

Check the manufacturer's data for your battery and ensure that the Maximum voltage of the profile you select does not exceed the manufacturer's recommended maximum charging voltage. If the Maximum voltage is too high for your battery type, please select another charging profile.

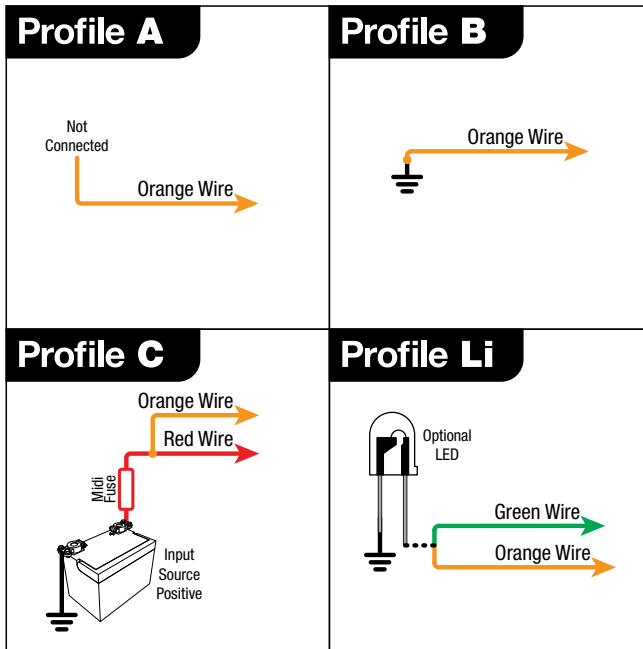

FIGURE 2.2.1: Charge Profile Selection

## 2 INSTALLATION

### 2.3 Input Trigger Settings (BLUE Wire)

The BLUE wire is used to switch the vehicle input turn ON trigger mode between:

- **Standard trigger** (for fixed voltage or temperature compensating alternators)
- **Low Voltage trigger** (for variable voltage alternators)

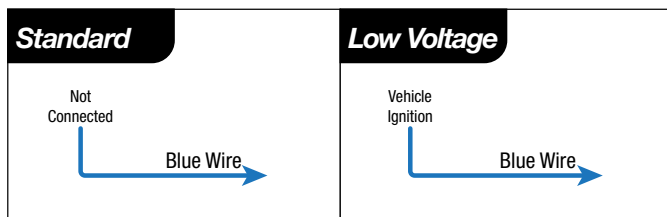

FIGURE 2.3.1: Setting the Input Trigger Settings

Input Mode	Blue Wire Connection	12 V Mode		24 V Mode	
		ON above	OFF below	ON above	OFF below
Standard	Not Connected	12.9 V	12.7 V	25.8 V	25.4 V
Low Voltage	Vehicle Ignition	12.0 V	11.9 V	24.0 V	23.8 V

If the Input Trigger (BLUE Wire) is connected to a signal other than the vehicle's Ignition signal, charging will only occur while the signal is active AND the Low Voltage Turn ON and OFF voltages in section 1.4 are valid. In some applications the BCDC could deplete the start battery to  $11.9 \text{ V} \pm 100 \text{ mV}$  or  $23.8 \text{ V} \pm 100 \text{ mV}$  for 12 V and 24 V vehicles respectively.

### 2.4 Cable sizing

Below is a table outlining the required cable size for a given cable install length.

Please refer to this table for Vehicle Input, Ground and Battery Output cable thickness requirements. Always choose a wire cross sectional area equal to or greater than what is specified below.

Part Number	Cable Install Length		Recommended Wire Cross Section (mm <sup>2</sup> )	Closest (BAE, B&S, AWG)
	(m)	(ft)		
BCDC1212T	1 – 5	3 – 16	5.26	10
	5 – 9	16 – 30	7.71	8

#### **⚠ CAUTION**

Cable and fuse sizes are specified by various codes and standards which depend on the type of vehicle the Battery Charger is installed into. Selecting the wrong cable or fuse size could result in harm to the installer or user and/or damage to the Battery Charger or other equipment installed in the system. The installer is responsible for ensuring that the correct cable and fuse sizes are used when installing this Battery Charger.

## 2 INSTALLATION

### 2.5 Wiring

The heavy gauge wires on the BCDC1212T unit carry peak currents of up to 25 Amps, and it is important to make good, low resistance, electrical connections that will not degrade over time. Failure to make a good, reliable contact may result in breakdown of the wire insulation and cause a short circuit, or worst case a fire. We recommend that this activity be undertaken by an appropriately qualified or experienced person.

The BCDC1212T brown and black wires are fitted with  $\frac{3}{16}$ " (M5) and  $\frac{5}{16}$ " (M8) lugs respectively for ease of installation. It is recommended that the BCDC1212T be installed as close as possible to the auxiliary battery it is charging to minimize cable length and associated voltage drop. Ideally the brown wire should be connected to the fuse on the auxiliary battery (see Figures 2.7.1 and 2.7.2) without adding additional length to the brown wire. The BCDC1212T black wire should be connected to a good quality ground. It is important that all the ground connections of the start battery, auxiliary battery, between the tow vehicle and trailer, and the BCDC1212T be high quality, have a low impedance between them and be corrosion free. The red (input) wire can be connected directly to the trailer plug's +12 V Auxiliary Power pin, provided that towing harnesses and connectors are suitably rated (see CAUTION in section 2.6)

### 2.6 Fusing

Fuses must be connected close to the start battery and the Auxiliary battery in order to protect the wiring and connectors between the batteries and the BCDC. REDARC recommends using MIDI style bolt down fuses as they ensure a low resistance connection. The REDARC FK23 and FK30 fuse kits are recommended.

Blade type fuses are not recommended as they can result in a high resistance connection which causes excess heat and may damage the fuse holder and/or the wiring.

Self-resetting circuit breakers are not recommended as they may trip prematurely due to the heat generated by the current flowing through the wires.

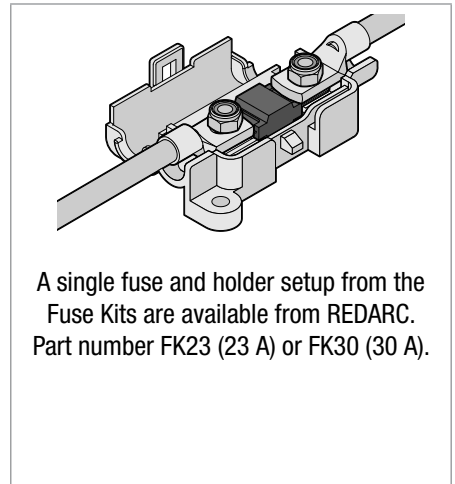

### **⚠ CAUTION**

In applications where the BCDC1212T draws power through the vehicle's and trailer's towing harnesses and connectors, the harnesses wiring gauge, connectors and fuse current ratings and fuse type should be checked by a suitably qualified person to ensure that it is adequately rated for safe and reliable operation and that the vehicle's fuse is appropriately rated and located to protect the wiring in the event of a fault, including short circuits.

2.7 **Typical Setup**

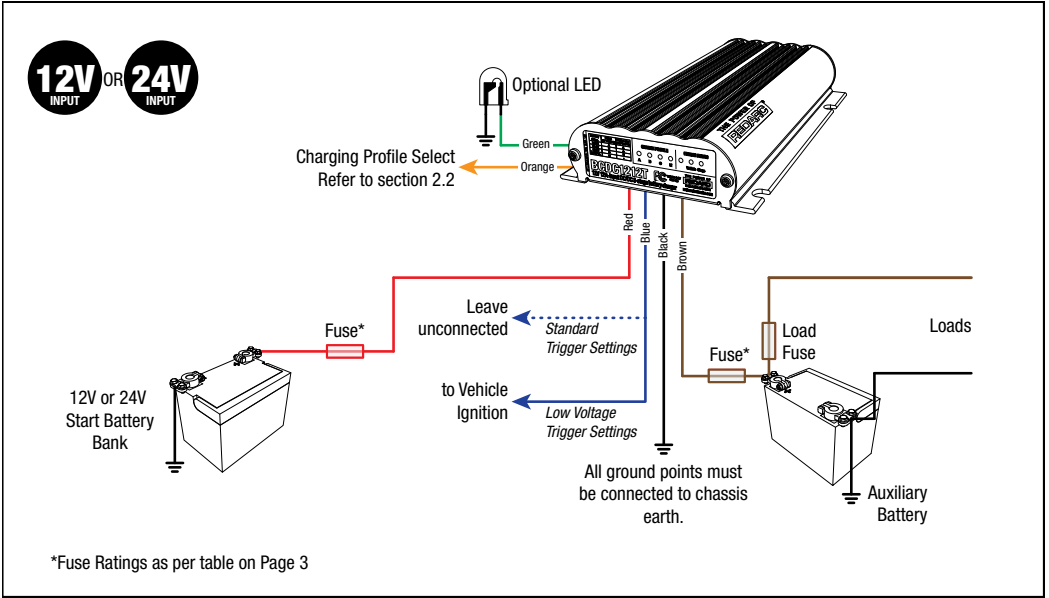

**FIGURE 2.7.1:** Typical Lead Acid type Setup

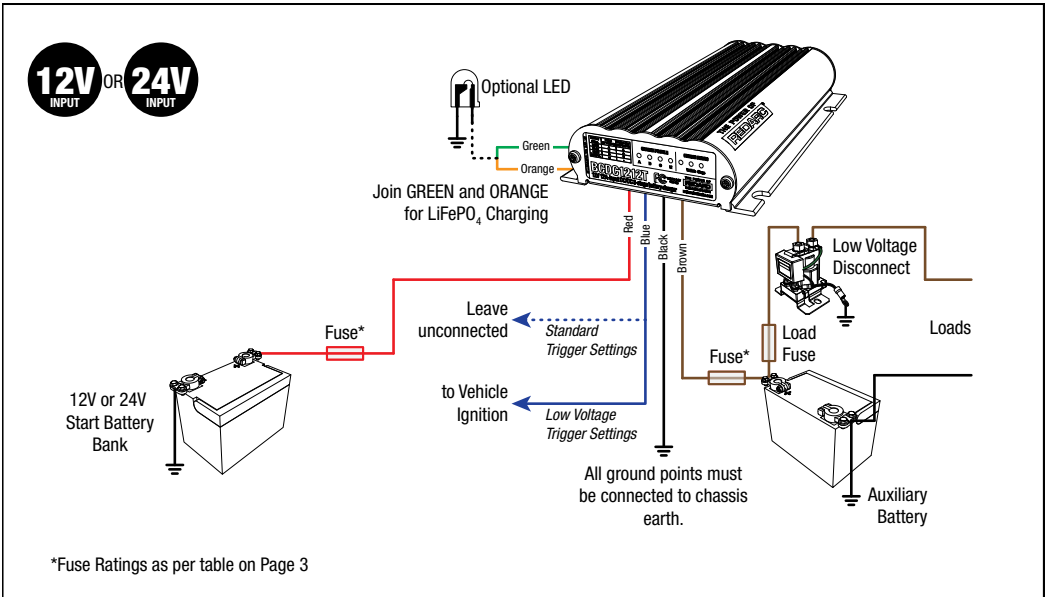

**FIGURE 2.7.2:** Typical LiFePO<sub>4</sub> Setup

### 3 TROUBLESHOOTING

#### THERE ARE NO LEDS ON AT ALL...

This indicates that there is no battery connected to the output (BROWN wire) or that battery is not at a suitable voltage level to be charged AND the input (RED wire) of the charger is not connected.

1. Check the Auxiliary battery is above 0.1 V
2. Check all wiring to the charger and battery, particularly the Ground (BLACK wire).
3. Check fuses are intact and properly connected.

If the problem is still evident please contact your local Auto-Electrician.

#### THE 'CHARGE PROFILE' LED IS FLASHING...

This indicates that either Output or Input is not valid.

Specifically, an Auxiliary battery, at a suitable voltage level to be charged, is connected to the output of the charger however there is currently no valid charging source OR a valid charging source is available but the Auxiliary battery is not at a suitable voltage level to be charged or is not connected.

1. Check that the Vehicle (RED wire) is electrically connected. The Vehicle (RED wire) should connect directly to the Vehicle battery positive terminal via an adequately rated fuse.
2. Check that the Ground (BLACK wire) is connected to the Auxiliary battery and Chassis Ground.
3. Disconnect any loads from the Auxiliary battery and check the Auxiliary battery is above 0.1V.
4. Check all wiring to the Auxiliary battery, particularly the Ground (BLACK wire).
5. Check fuses are intact and properly connected.

If the problem is still evident please see the relevant points below.

#### THE BCDC IS CONNECTED TO THE 'VEHICLE' BUT THE VEHICLE LED IS OFF...

This indicates that the required turn ON conditions for this source have not been met. With the BLUE wire left unconnected, the voltage at the RED wire must be above 12.9 V for a 12 V installation or above 25.8 V for a 24 V installation. With the BLUE wire connected to Ignition, Ignition must be on and the voltage at the RED wire must be above 12.0 V for a 12 V installation or above 24.0 V for a 24 V installation.

1. Check that the vehicle is running.
2. Check the voltage on the RED wire is above the required turn ON threshold for your installation (See section 1.4 on page 7).
3. Check all wiring to the Vehicle battery, particularly the Ground (BLACK wire).

If the problem is still evident please contact your local Auto-Electrician.

### 4 CHECKING THE PRODUCT SERIAL NUMBER

The images indicate where the Product Serial Number on the Main Unit and on the Product Packaging.

The Serial Number Label contains the Part Number (circled in BLUE) and the Serial Number (circled in RED).

The first 4 digits of the serial number indicate the YEAR and MONTH of manufacture, in the form YYMM.

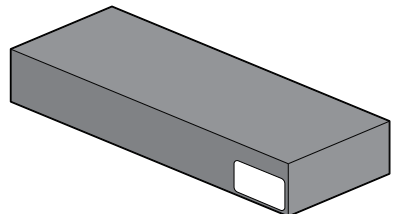
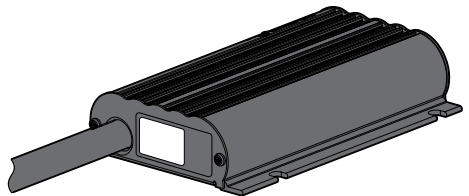

## 5 FCC DECLARATION

---

This device complies with part 15 of the FCC Rules. Operation is subject to the following two conditions: (1) This device may not cause harmful interference, and (2) this device must accept any interference received, including interference that may cause undesired operation.

Note: This equipment has been tested and found to comply with the limits for a Class B digital device, pursuant to part 15 of the FCC Rules. These limits are designed to provide reasonable protection against harmful interference in a residential installation. This equipment generates, uses and can radiate radio frequency energy and, if not installed and used in accordance with the instructions, may cause harmful interference to radio communications. However, there is no guarantee that interference will not occur in a particular installation. If this equipment does cause harmful interference to radio or television reception, which can be determined by turning the equipment off and on, the user is encouraged to try to correct the interference by one or more of the following measures:

- Reorient or relocate the receiving antenna.
- Increase the separation between the equipment and receiver.
- Connect the equipment into an outlet on a circuit different from that to which the receiver is connected.
- Consult the dealer or an experienced radio/TV technician for help.

## 6 FREQUENTLY ASKED QUESTIONS

---

**Q** The BCDC turns ON at 12.9 V (12 V) and OFF at 12.7 V (11.9 V), but you say it operates down to 9 V, explain?

**A** The BCDC will turn OFF for a split second every 100 seconds to measure the unloaded voltage at the battery. When the BCDC turns off it is not drawing any load from the start battery, no load means that there is no voltage drop over the cable run. This allows the BCDC to measure the actual battery voltage, or the voltage at the battery. If this actual battery voltage is below 12.7 V (11.9 V), the BCDC will turn OFF. At any other time during the charging process, if the voltage at the BCDC drops below 9 V the BCDC will turn OFF.

**Q** How does the BCDC charge an Auxiliary battery at 14 V when it only gets 9 V in?

**A** The BCDC can act as both a reducer and a booster, so it can operate from a voltage of above, equal to or below the desired output voltage. The unit is also microprocessor controlled allowing it to output a REDARC proprietary charging algorithm independent of the input. This allows the unit to charge specific to the battery type even if the input voltage is low due to voltage drop.

**Q** Where should I mount the BCDC Unit?

**A** The BCDC should be mounted as close as possible to the battery being charged (generally called the Auxiliary or House battery). If the Auxiliary battery is located under the bonnet, pick a location for the BCDC that is close to the battery and away from any direct engine heat. If the BCDC is to be mounted into a Caravan or Camper, near or in the battery compartment is generally the best position. It is also a good idea to mount the BCDC to a metal surface if possible, to ensure optimal heat dissipation, though this is not crucial.

**Q** What does the charger do if the temperature around it rises above its operating temperature?

**A** As the temperature of the BCDC rises above a certain level the current capacity of the output is decreased gradually in order to protect both the battery and the BCDC unit.

**Q** If I use the BCDC to charge my auxiliary battery do I still need to install a battery isolator?

**A** The BCDC incorporates the functionality of a battery isolator, it will turn ON and start charging when it senses that the vehicle has started and similarly it will turn OFF when the vehicle is turned OFF.

**Q** I've heard that you shouldn't charge 2 batteries of different chemistries from the same source, will I have any problems charging my AGM or Gel auxiliary battery from my Lead Acid start battery?

**A** The BCDC does not 'link' the batteries together like a battery isolator does, it is a DC-DC battery charger. The output from the unit is tailored specifically to the selected output battery type, and therefore allows the optimal charging of the auxiliary battery, no matter what chemistry your start battery is.

**Q** My BCDC is setup for 12 V Alternator input but will not start when the vehicle is turned On, I've followed the trouble shooting guide and the setup is fine, what's the problem?

**A** The most likely cause of this issue is that the BCDC is somehow 'stuck' in 24 V mode. Try removing the 'Vehicle' (RED) wire and reconnecting it. If the problem still exists please contact REDARC Corporation.

# 7 TWO YEAR PRODUCT WARRANTY — NORTH AMERICA

Over the last four decades our company has established a reputation as the power conversion specialist.

A 100% Australian-owned company, we have met the needs of customers in transport and other industries through exciting, innovative thinking. We believe in total customer satisfaction and practice this by offering our customers:

- Technical advice free of jargon and free of charge
- Prompt turnaround of orders
- Friendly, personalized, professional service and product support

In the unlikely event that a technical issue arises with a REDARC product, customers are encouraged to initially contact the REDARC Technical Support Team at the phone number and e-mail listed in clause 24 for prompt and efficient diagnosis and product support.

REDARC Corporation ("REDARC") offers a warranty in respect of its Products purchased from an authorized distributor or reseller of REDARC by a person who is the original retail purchaser ("Purchaser"), on the terms and conditions, and for the duration, outlined below in this document ("Warranty").

1. In this Warranty, the term "Products" means:

- 1.1 all new products manufactured or supplied by REDARC (excluding its solar products which are covered by REDARC's Solar Product Warranty); and
- 1.2 any component of or accessory for any product in clause 1.1 manufactured or supplied by REDARC.

## Offer and duration of product warranties

2. REDARC warrants that its Products will be free, under normal application, installation, use and service conditions, from defects in materials and workmanship affecting normal use, for 2 years from the date of purchase ("Warranty Period").
3. The replacement of any component or part of your unit under warranty will not extend the period of warranty.
4. Where a Product malfunctions or becomes inoperative during the Warranty Period, due to a defect in materials or workmanship, as determined by REDARC, REDARC will, in exercise of its sole discretion, either repair or replace the defective Product. If REDARC determines that the defective Product cannot be repaired or replaced, then REDARC will provide a refund to the Purchaser for the purchase price paid for the defective Product. REDARC will cover any shipping cost for replacement.
5. For purposes of clarity, "repair or replace the defective Product" does not include any removal or reinstallation costs or expenses, including, without limitation, any labor costs or expenses, shipping costs to return non-conforming Products or any damages that may occur during the return of Product to REDARC.
6. The remedies set forth herein constitute the exclusive and maximum liability of REDARC, to the extent permitted by applicable law, with respect to the manufacture, sale, delivery, installation, operation or use of the Products, whether arising out of contract, negligence, tort or under any warranty or other legal theory.

## Exclusions and limitations

7. This Warranty will not apply to, or include any defect, damage, fault, failure or malfunction of a Product, which REDARC determines, in exercise of its sole discretion, to be due to:
  - 7.1 normal wear and tear or exposure to weather conditions over time;
  - 7.2 accident, misuse, abuse, negligence, vandalism, alteration or modification;
  - 7.3 used or second-hand products;
  - 7.4 non-observance of any of the instructions supplied by REDARC, including instructions concerning installation, configuring, connecting, commissioning, use or application of the Product, including without limitation choice of location;
- 7.5 failure to ensure proper maintenance of the Product strictly in accordance with REDARC's instructions or failure to ensure proper maintenance of any associated equipment or machinery;
- 7.6 repairs to the Product that are not strictly in accordance with REDARC's instructions;
- 7.7 installation, repairs or maintenance of the Product by, or under the supervision of, a person who is not a qualified auto electrician or technician, or if non-genuine or non-approved parts have been fitted;
- 7.8 faulty power supply, power failure, electrical spikes or surges, lightning, flood, storm, hail, extreme heat, fire or other occurrence outside the control of REDARC; or
- 7.9 use other than for any reasonable purpose for which the Product was manufactured.
- 7.10 use or installation in violation of the instructions or restrictions prescribed by any applicable standard or code, including those contained in the latest National Electrical Code, Standards for Safety of Underwriters Laboratory, Inc. (UL) the American National Standards Institute (ANSI), or the Canada Standards Association (CSA).

## 8. REDARC shall not be liable for:

- 8.1 any loss of profit, direct, indirect, special, penalty, incidental, secondary, contingent or consequential damages or expenses of any kind resulting from a breach of this warranty, including without limitation damages resulting from loss of use, profits, business or goodwill, even if REDARC was advised of or was otherwise aware of the possibility of such damages.
- 8.2 service, labor, installation or delivery charges incurred in removing or replacing a Product.

9. Warranty claims in respect of a Product must be made in writing to REDARC and received at the postal address or email address specified in clause 24 within the Warranty Period. Such claims must include the following:

- 9.1 details of the alleged defect or fault and the circumstances surrounding the defect or fault;
- 9.2 evidence of the claim, including photographs of the Product (where the subject of the claim is capable of being photographed);
- 9.3 the serial number of the Product, specified on the label affixed to the Product; and
- 9.4 proof of purchase documentation for the Product from an authorized distributor.
10. The return of any Products without the prior written instructions of REDARC will not be accepted by REDARC.
11. Without limiting any other clause in this Warranty, REDARC has the right to reject any Warranty claim made by a Purchaser pursuant to this Warranty where:
  - 11.1 the Purchaser does not notify REDARC in writing of a Warranty claim within the Warranty Period;
  - 11.2 the Purchaser does not notify REDARC in writing of a Warranty claim within 1 month of becoming aware of the relevant circumstances giving rise to the claim, so that any further

problems with the Product are minimized;

- 11.3 the serial number of the Product has been altered, removed or made illegible without the written authority of REDARC;
- 11.4 the Purchaser is unable to provide proof of purchase documentation in accordance with clause 7.4 or evidence that the Product was properly installed and removed (if relevant), and that proper maintenance has been performed on the Product, by or under the supervision of, a qualified auto electrician or technician, in accordance with the instructions of REDARC.
12. If the Product is found to be working satisfactorily on return to REDARC or upon investigation by REDARC, the Purchaser must pay REDARC's reasonable costs of testing and investigating the Product in addition to shipping and transportation charges. Where REDARC is in possession of the Product, the Product will be returned to the Purchaser on receipt of the amount charged.
13. Any replaced Products or components of Products shall become the property of
14. REDARC may, in exercise of its sole discretion, deliver another type of Product or component of a Product (different in size, color, shape, weight, brand and/or other specifications) in fulfilling its obligations under this Warranty, in the event that REDARC has discontinued manufacturing or supplying the relevant Product or component, so long as the replacement Product or component performs at substantially the same level and carries out substantially the same function as the Product or component being replaced.

## Other conditions of Warranty

15. If the Purchaser acquired a Product for the purpose of resupply, then this Warranty shall not apply to that Product. In particular, the sale of a Product via an online auction, online store or other internet website by a party that is not an authorized distributor or reseller of the Product will be deemed to be a resupply and will render this Warranty void.
16. A Purchaser shall only be entitled to the benefit of this Warranty after all amounts owing in respect of the Product have been paid.
17. To the maximum extent permitted by law, REDARC does not warrant that the operation of the Products will be uninterrupted or error-free.
18. To the maximum extent permitted by law, REDARC's determination of the existence of any defect and the cause of any defect will be conclusive.
19. The agents, officers and employees of any distributor or reseller of the Products and of REDARC are not authorized to vary or extend the terms of this Warranty.
20. REDARC shall not be responsible or liable to the Customer or any third party in connection with any non-performance or delay in performance of any terms and conditions of this Warranty, due to acts of God, war, riots, strikes, warlike conditions, plague or other epidemic, fire, flood, blizzard, hurricane, changes of public policies, terrorism and other events which are beyond the control of REDARC. In such circumstances, REDARC may suspend performance of this Warranty without liability for the period of the delay reasonably attributable to such causes.
21. Except for the foregoing Warranty, there are no other representations, conditions or warranties express or implied with respect to the Products, including representations, conditions or warranties of merchantability, fitness for a particular purpose or non-infringement which conditions, representations and warranties are expressly disclaimed, to the extent permitted by applicable law.
22. REDARC reserves the right to use new, reconditioned, refurbished, repaired or remanufactured products or parts in the repair or replacement of any Product covered by this Warranty.
23. If a clause or part of a clause in this Warranty can be read in a way that makes it illegal, unenforceable or invalid, but can also be read in a way that makes it legal, enforceable and valid, it must be read in the latter way. If any clause or part of a clause in this Warranty is illegal, unenforceable or invalid, that clause or part is to be treated as removed from this Warranty, but the rest of this Warranty is not affected.

## REDARC's contact details

24. REDARC's contact details for the sending of Warranty claims under this Warranty are:

REDARC Corporation  
c/o SHALLCO, INC.  
308 Component Dr.  
Smithfield, NC 27577  
Email: [power@redarcelectronics.com](mailto:power@redarcelectronics.com)  
Telephone: +1 (704) 247-5150 if you are calling from the USA  
+52 (558) 526-2898 if you are calling from Mexico  
+1 (604) 260-5512 if you are calling from Canada

(calls are answered between 8:00 a.m. and 5:30 p.m. Australian Central Standard Time (ACST))

25. REDARC reserves the right to modify this Warranty from time to time and any modifications shall be effective for all orders placed on or after the effective date of such revised warranty. Some states, provinces or territories do not allow exclusion or limitation of certain types of damages, or permit limitations on the length of implied warranties, so certain of these warranty limitations may not apply to the Purchaser. This Warranty gives the Purchaser specific legal rights. The Purchaser may also have other rights which vary from state to state, province to province or territory to territory. If any term of this Warranty is held to be illegal or unenforceable, the legality and enforceability of the remaining terms shall not be affected or impaired. This Warranty allocates risk of Product failure between the Purchaser and REDARC, and REDARC's Product pricing reflects this allocation of risk and the limitations of liability contained in this Warranty.

**UNDER NO CIRCUMSTANCES SHALL REDARC'S AGGREGATE LIABILITY ARISING OUT OF OR IN CONNECTION WITH A DEFECTIVE PRODUCT, IN CONTRACT, TORT OR OTHERWISE, EXCEED THE PURCHASE PRICE OF THE PRODUCT TO WHICH SUCH LIABILITY RELATES.**

## FREE TECHNICAL ASSISTANCE

For product and technical support contact your regional distributor, call our head office between 8:00 a.m. to 5:30 p.m. Australian Central Standard Time, Monday to Friday, or send us an e-mail.



### **Australia (and other Global regions)**

power@redarc.com.au  
www.redarc.com.au  
+61 8 8322 4848

### **New Zealand**

power@redarcelectronics.co.nz  
www.redarcelectronics.co.nz  
+64 9 222 1024

### **North America**

power@redarcelectronics.com  
www.redarcelectronics.com

### **United States**

+1 (704) 247-5150

### **Canada**

+1 (604) 260-5512

### **Mexico**

+52 (558) 526-2898

### **UK/Europe**

power@redarcelectronics.eu  
www.redarcelectronics.eu  
+44 (0)20 3930 8109

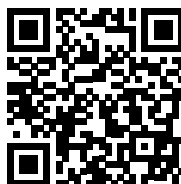

Para ver el  
manual en  
Español

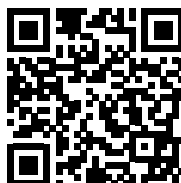

Pour accéder  
au manuel  
d'utilisation  
en Français

**www.redarcelectronics.com**