



Nissan Patrol ZD30 2007 – onwards

Direction-Plus™ Pre-Filter Kit Installation Guide

This document is to be used as a guide for the installation of the Direction-Plus™ Fuel Manager™ FM100 pre-filter Kit to a Nissan Patrol ZD30. It is recommended that the installation of the product be carried out by a competent qualified mechanic.

Important before starting

- Ensure the engine bay is clean and free from contaminates
- The fuel manager filter head has direction arrows indicating the direction of flow
- You have the correct tools to complete the fitment
- Read the instructions in full and familiarize yourself with the installation, before commencing any work

Kit contents

1/4" NPT STRAIGHT - 10MM 2 BOLTS 2 NUTS 4 WASHERS	2
BRACKET - PATROL 3.0lt C/R (2007-ON)	1
DFL10 - FUEL LINE RUBBER (10MM)	1
DP733-04 - 1/4 "NPT PLUG	4
ELEMENT ASSEMBLY 30M - 3.6"	2
FM ENGINE BAY LABEL	1
FM100 30 MICRON FILTER ASSY	1
FUEL MANAGER KIT	1
HOSE CLAMP - 10MM	2
LOCTITE 567 THREAD SEALANT - 6ML	2
PUSH ON STRAIGHT - 10MM	1
WINDSCREEN LABEL	1

Pre-filter mounting locations

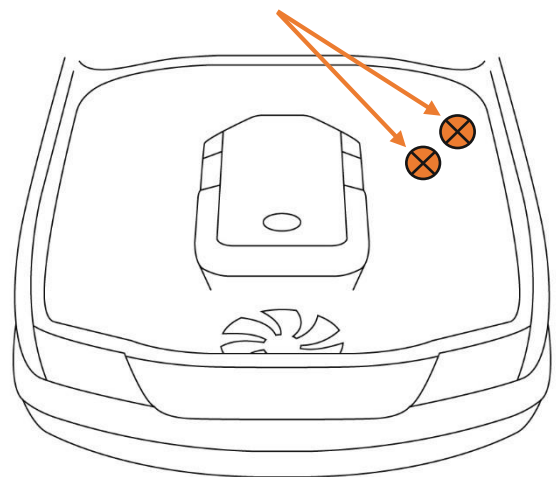

*Kit contents are subject to change based on component availability and/or refinement

Fuel Manager Pre-Filter Normal Flow Header Connection

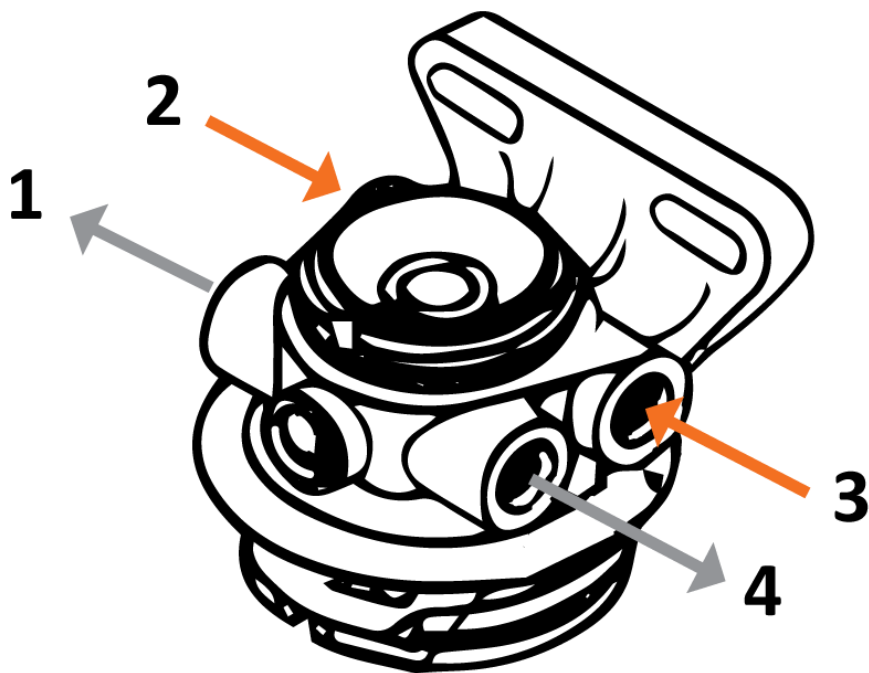

Ports 2 and 3 = INLET
Ports 1 and 4 = OUTLET



Installation Guide

1. The pre-filter mounting bracket mounts on the firewall side of the black bracket that is located on the inner guard on the passenger side of the vehicle
2. Mount the pre-filter bracket using the top clamp bolt for the air-conditioner pipe as well as the holes in the pre-filter mounting bracket

Note: in some applications, it may be required to drill new holes in the pre-filter mounting bracket
3. Secure the pre-filter mounting bracket in place using supplied 6mm bolts and nyloc nuts
4. Using the supplied 10mm bolts, washers and nuts, mount the FM100 Fuel Manager pre-filter assembly filter to the backside of the bracket
5. Install the ¼ NPT adaptors into the filter head ports that are facing towards the center of the vehicle using the supplied LOCTITE thread sealant.
6. Apply a small amount of LOCTITE thread sealant to the two black ¼ NPT plugs and install them into the two remaining ports of the pre-filter head.
7. Measure from the steel pipe on the firewall (this pipe comes from the tank) to the inlet port of the fuel manager head (the arrows on the head indicate direction of flow) and cut to length a piece of the supplied 10mm hose
8. Lubricate the barbed end of one push-lock fitting and the inside portion of the hose to be fitted with a push-lock fitting with diesel fuel or WD40
9. Insert the barbed end of one push-lock fittings into the pre-lubricated end of the hose. Ensuring that the hose stops firmly against the inside of the bell cover.
10. With the assembled hose, screw the push-lock fitting on to the inlet port of the pre-filter. Connect the other end of the same hose to the steel fuel line coming from the tank and secure using a supplied 10mm hose clamp
11. Lubricate the barbed end of the remaining push-lock fitting and the inside portion of the remaining hose to be fitted with a push-lock fitting with diesel fuel or WD40
12. Insert the barbed end of the remaining push-lock fittings into the pre-lubricated end of the hose. Ensuring that the hose stops firmly against the inside of the bell cover.
13. With the now assembled hose, screw the push-lock fitting on to the outlet port of the pre-filter.
14. Measuring the hose in place between the outlet port of pre-filter the inlet of the factory fuel filter, cut the hose to length
15. Connect the 10mm fuel hose to the inlet of the factory fuel filter and secure with a supplied 10mm hose clamp



16. Using the supplied nylon cable ties, secure any loose hose from rubbing on any other components

17. Prime the system using the hand primer on the factory filter until the primer button is firm, the engine is ready to start.

18. Start vehicle and run the vehicle, whilst checking all connections for leaks

END OF GUIDE