



TOYOTA Hilux 1GD-FTV

Direction-Plus™ Pre-Filter Kit Installation Guide

This document is to be used as a guide for the installation of the Direction-Plus™ Fuel Manager™ FM100 pre-filter Kit to a Toyota Hilux D4D. It is recommended that the installation of the product be carried out by a competent qualified mechanic.

Important before starting

- Ensure the engine bay is clean and free from contaminants
- The fuel manager filter head has direction arrows indicating the direction of flow
- You have the correct tools to complete the fitment
- Read the instructions in full and familiarize yourself with the installation, before commencing any work

Kit contents

1/4" NPT STRAIGHT - 10MM 2 BOLTS 2 NUTS 4 WASHERS	2
BOLT - 6X25MM ZINC	1
BRACKET - HILUX 2.8	1
CABLE TIE 280 X 4.8 (UV)	1
DFL10 - FUEL LINE RUBBER (10MM)	1
DP733-04 - 1/4 "NPT PLUG	2
ELEMENT ASSEMBLY 30M - 3.6"	1
FM ENGINE BAY LABEL	1
FM100 30 MICRON FILTER ASSY	1
HOSE CLAMP - 10MM	2
LOCTITE 567 THREAD SEALANT - 6ML	1
NUT - NYLOC 6MM	1
PUSH ON 90 DEG - 10MM	2
WINDSCREEN LABEL	1

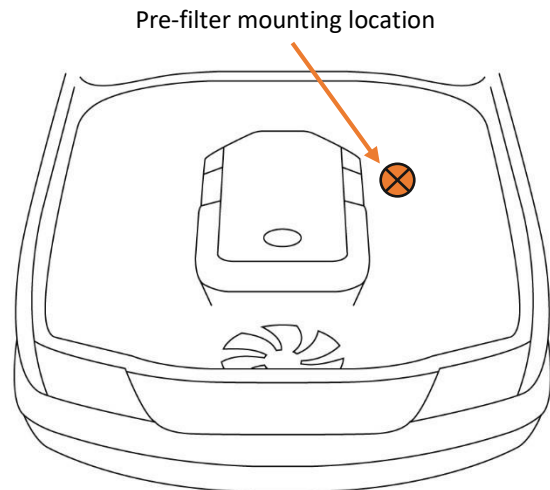

*Kit contents are subject to change based on component availability and/or refinement

Fuel Manager Pre-Filter Normal Flow Header Connection

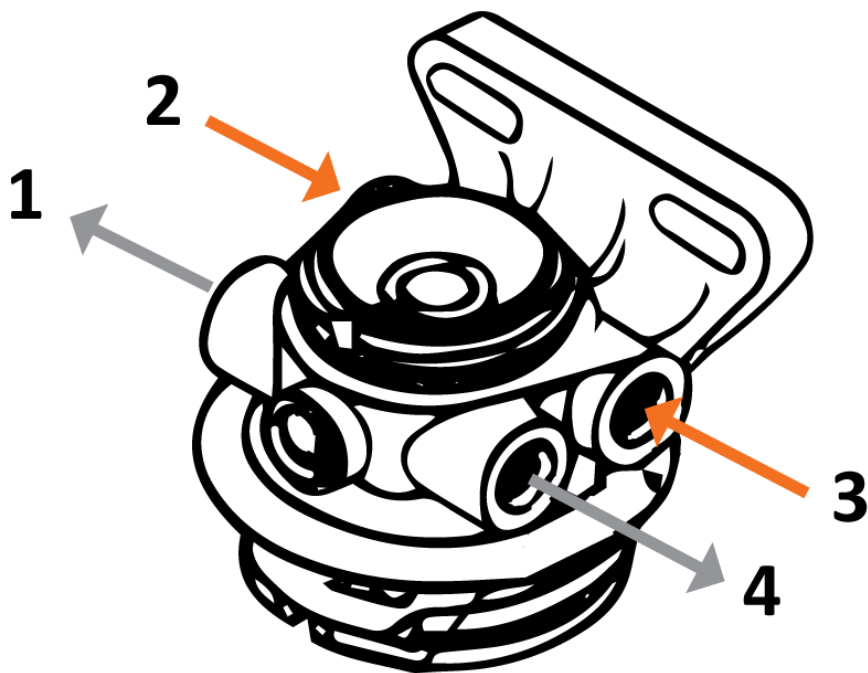

Ports 2 and 3 = INLET
Ports 1 and 4 = OUTLET



Installation Guide

1. Disconnect the electrical connector from the factory fuel filter.
2. There is a clip holding a cable onto the factory mounting bracket, remove this clip from the bracket.
3. Remove the bolt that is holding the ECU beside the factory fuel filter bracket. Remove the wiring harness from the holding bracket by squeezing the two (2) lugs on the engine side of the bracket.
4. Remove the five (5) retaining bolts that are holding the factory filter bracket. Discard the factory fuel filter bracket.
5. Mount the Direction Plus bracket into place using the existing five (5) mounting bolts from the original bracket. There is one (1) extra bolt supplied, use this in the lower bracket.
6. Mount the factory/ original fuel filter onto the Direction plus bracket. The cable is now mounted on the left hand side of the bracket near the fuse box. Reconnect the electrical connector and harness clip.
7. Mount the ECU onto the top right-hand side of the Direction Plus bracket.
8. Ensuring you have a push-lock barb fitting (supplied) on the INLET and OUTLET side, install the ¼ NPT barb fittings into the Direction Plus filter assembly using the supplied LOCTITE thread sealant.
9. Mount the Pre-Filter and head (black) to the Direction Plus bracket using the supplied 10mm bolts, washers and nuts.
10. Lubricate the barbed end of one (1) of the push-lock fittings and the inside portion of the hose to be fitted with a push-lock fitting with diesel fuel or WD40.
11. Disconnect the INLET hose from the factory fuel filter and fit this to the push-lock barb fitting on the OUTLET side of the Direction Plus Pre-Filter ensuring that the hose is firmly stopped against the inside of the bell cover.
12. Insert the barbed end of one (1) of the push-lock fittings into the pre-lubricated end of the hose. Fit this to the INLET side of the Direction Plus Pre-Filter ensuring that the hose is firmly stopped against the inside of the bell cover. Secure the other end of this fuel hose to the factory steel fuel line with the supplied hose clamp.
13. Apply a small amount of LOCTITE thread sealant (supplied) to the two (2) remaining black ¼ NPT plugs and install them in to the two (2) remaining ports on the Direction Plus pre-filter head/ assembly.
14. Ensure all fuel lines are suitably secured.
15. Using the supplied nylon cable ties, secure any loose hose to prevent it from rubbing against any other components.
16. Prime the fuel system by using the factory primer until it is firm, the engine is now ready to start.
17. Start and run the engine whilst checking ALL connections for leaks.

END OF GUIDE