

Toyota Land Cruiser 70 Series 1VD-FTV (2018-2022) Direction-Plus™ FUEL MANAGER Installation Guide

This document is to be used as a guide for the installation of the **Direction-Plus™ Fuel Manager FUEL MANAGER pre-filter** to a **2018 onwards Toyota Land Cruiser 70 Series V8 Diesel 1VD-FTV (2018-2022)**. It is recommended that the installation of the product be carried out by a competent qualified mechanic.

Important Before Starting

- Ensure you have the correct tools to complete the fitment
- Read the instructions in full and familiarize yourself with the installation, before commencing any work

Maintenance / servicing

- It is recommended to drain the FUEL MANAGER element every 5,000 – 10,000km
- FUEL MANAGER element is to be replaced every 40,000km or as per your vehicles service interval

Included in the kit

1 x Mounting Bracket
1x Fuel Manager assembly
1x 8mm x 17mm washer
1x M8x16 bolt
1x 8mm spring washer
2x M10 Bolts
4x M10 Washers
2X M10 Nyloc Nuts
2x M6x16 Bolts
4x M6 Flat Washers
2x M6 Nyloc Nuts
1x 3m Length of 12mm Fuel Hose
2x 12mm Fuel Hose Clamps
2x Push on Straight 12mm
2x 1.5m Length of 35mm Heat Sleeve
2x 12mm Straight Push-Lock
1x Thread Sealant
4 Washers
2x Blanking Plugs
Cable Tier
1x Windscreen Label
1x Engine Bay Label

Approximate mounting location

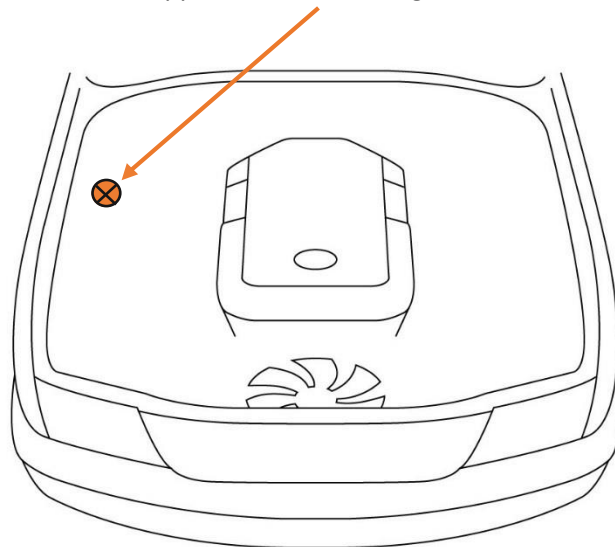

*Kit contents are subject to change based on component availability and/or refinement

Fuel Manager Pre-Filter Normal Flow Header Connection

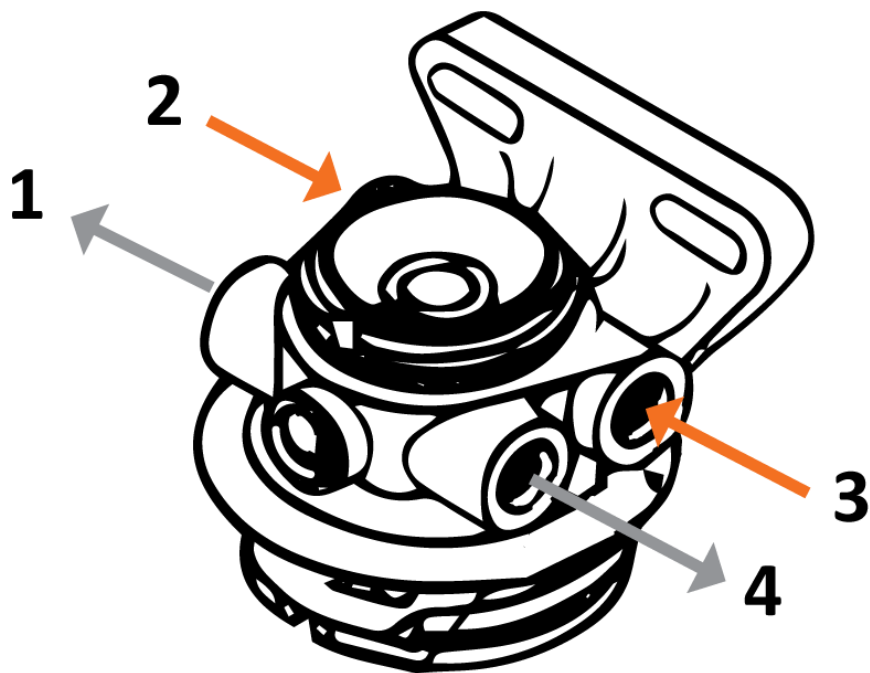

Ports 2 and 3 = INLET
Ports 1 and 4 = OUTLET

Installation Guide – Fuel Manager Pre-Filter Kit

1. Using the supplied 10mm bolts, washers and nuts, mount the Fuel Manager pre-filter assembly filter to rear mounting location of the bracket
2. Install the two Push on straight 12mm to the filter head, so that when the filter is mounted on the bracket, they will both be facing toward the rear of the vehicle
3. Install the two blanking plugs into the remaining ports.

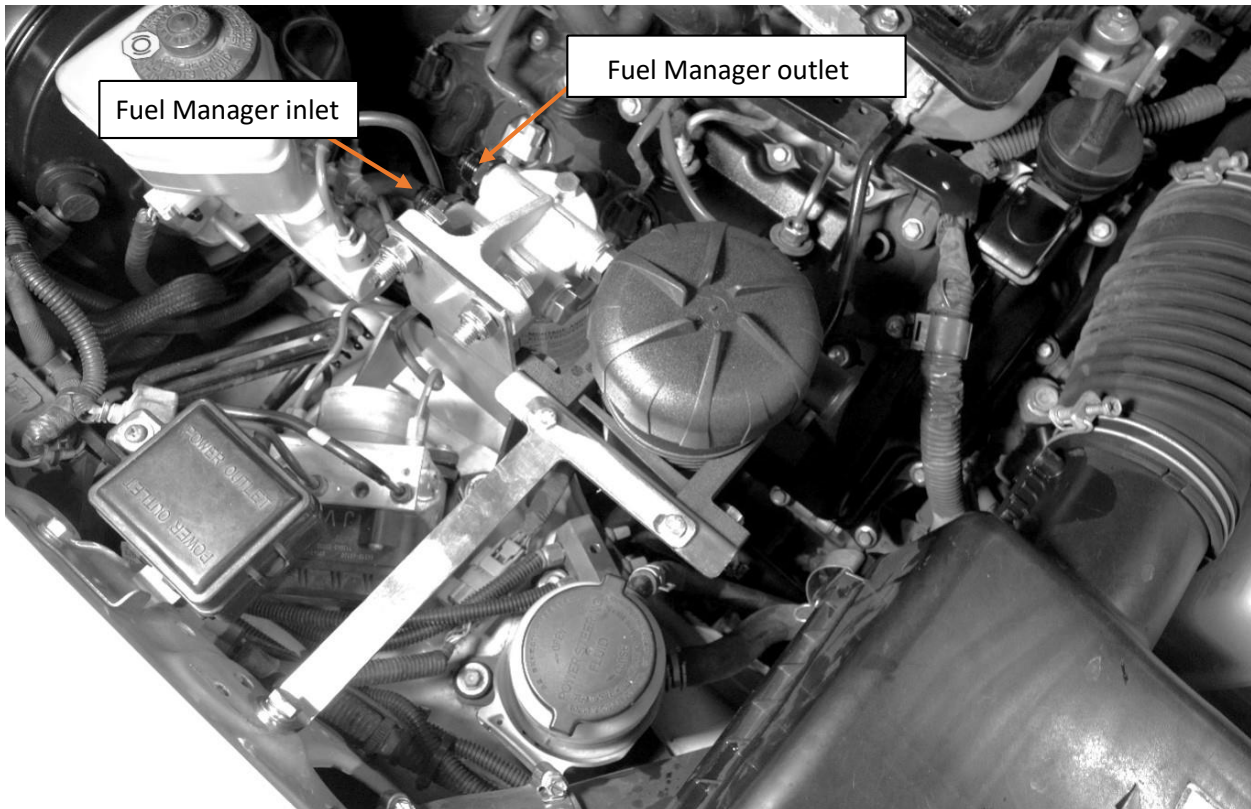

4. Remove the factory fuel filter supply hose. Retain this hose if you wish to remove the kit at any point.

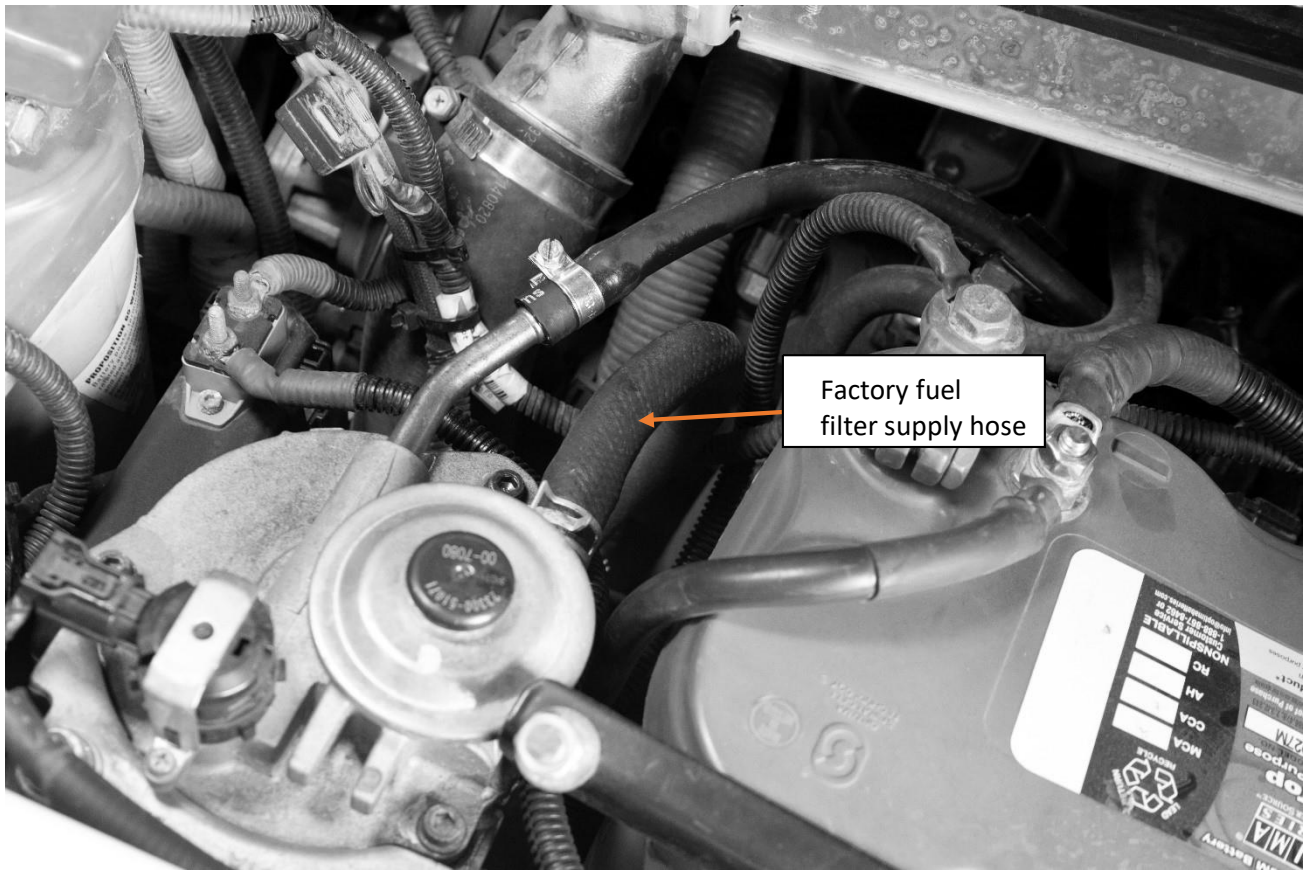

5. Measure from the steel pipe (this pipe comes from the tank) to the inlet port of the FUEL MANAGER head (the arrows on the head indicate direction of flow) and cut to length a piece of the supplied 12mm hose
6. Lubricate the barbed end of one push-lock fitting and the inside portion of the hose to be fitted with a push-lock fitting with diesel fuel or WD40
7. Insert the barbed end of one push-lock fittings into the pre-lubricated end of the hose. Ensuring that the hose stops firmly against the inside of the bell cover.
8. Install a length of the supplied heat shield over the hose – trim to length if required
9. With the assembled hose, screw the push-lock fitting on to the inlet port of the pre-filter. Routing the hose along the firewall, Connect the other end of the same hose to the steel fuel line coming from the tank and secure using a supplied 12mm fuel hose clamp

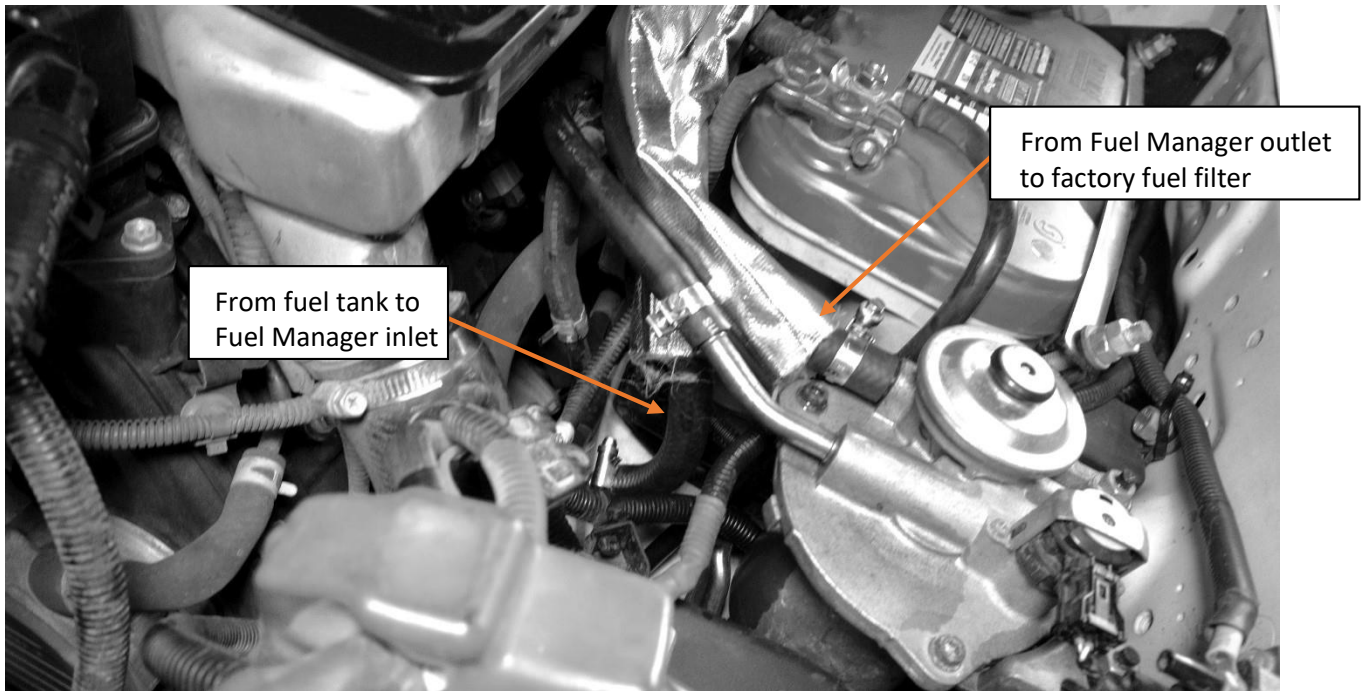

10. Lubricate the barbed end of the remaining push-lock fitting and the inside portion of the remaining hose to be fitted with a push-lock fitting with diesel fuel or WD40
11. Insert the barbed end of the remaining push-lock fittings into the pre-lubricated end of the hose. Ensuring that the hose stops firmly against the inside of the bell cover
12. Install a length of the supplied heat shield over the hose – trim to length if required
13. With the now assembled hose, screw the push-lock fitting on to the outlet port of the pre-filter
14. Routing the hose along the firewall, measuring the hose in place between the outlet port of pre-filter the inlet of the factory fuel filter. Cut the hose to length

15. Connect the 12mm fuel hose to the inlet of the factory fuel filter and secure with a supplied 12mm fuel hose clamp
16. Using the supplied nylon cable ties, secure any loose hose from rubbing on any other components
17. Bleed the fuel system by pumping the hand primer on the factory filter until firm – **NOTE: it is easier to prime the system if the Fuel Manager element is filled with clean diesel before using the hand primer.**
18. Start vehicle and run the vehicle, whilst checking all connections for leaks

End of Fuel Manager Installation Guide