



ELITE 3-LOOP WINCH BAR

FITTING INSTRUCTIONS



ISUZU D-MAX 2017-2019

PK105FG1ID17E_RMB

PK105FG1ID17E_RO

Fitting Time : approx. 3.5-4 hours



BULL BAR SAFETY NOTICE:

INSTALLATION SHOULD ONLY BE DONE BY APPROPRIATELY QUALIFIED OR EXPERIENCED PERSONS IN ACCORDANCE WITH THESE INSTRUCTIONS.

IT IS THE RESPONSIBILITY OF THE INSTALLER TO ENSURE THAT THE PRODUCT IS CORRECTLY FITTED.

WARNING:

- Do not attach Vehicle Frontal Protection System (**VFPS**) to the vehicle using anchorages not intended for this purpose. (e.g. engine mounting bolts)
- Do not use this product for any vehicle make or model, other than those specified by the VFPS manufacturer.
- Do not remove the plaque or label from the VFPS.
- Do not modify the structure of the VFPS in any way.
- The VFPS has been produced to provide continued functionality of parking sensors and other "driver assist" features as closely as possible to Original Equipment. However, as all possible road conditions and combination of other accessories fitted to the vehicle which may affect functionality characteristics cannot be anticipated, ***the driver remains responsible at all times for properly controlling the vehicle, monitoring all "driver assist" features and intervening where required to ensure the vehicle is safely operated.***

IMPORTANT INFORMATION:

- Before installing the VFPS:
 - Check that all components, as listed in the assembly table, are available.
 - Thoroughly read all instructions.
- This product or its fasteners must not be modified in any way.
- These instructions are accurate as at the revision date and do not take into account any changes made by the vehicle manufacturer to vehicle design after the revision date or other accessories that are or have been fitted to the vehicle. Piak cannot be held responsible for such changes and appropriate enquiries should be made before installation.
- Before installing, inspecting and/or maintaining the VFPS, the work space should be safe and clear of fuel, debris, electrical or other components.
- During installation:
 - It is the responsibility of the installer to confirm correct operation/clearance of all components.
 - All holes drilled shall have all burrs and swarf removed then coated with a suitable rust preventative paint.
 - Ensure that all hardware is fastened to torque list as detailed in these instructions.

MAINTENANCE AND CARE:

To ensure continued safety and correct operation of the product, the VFPS must be routinely inspected and regularly serviced (including bolt torque checked for correct tension) by an appropriately qualified or experienced person.

The high tensile fasteners supplied with this product were used to achieve the specified rating. If replacement of the fasteners is required, fasteners of the same rating and quality must be used.

If this VFPS is fitted with a hinged number plate bracket, extra care must be taken when returning back to public roads following the use of the winch or conducting a deep water crossing.

The driver must ensure that the number plate bracket is returned back to the down position allowing full visibility of the number plate when returning to public roads.

EQUIPMENT:

These safety products should, at a minimum, be used when fitting or working on the product.



Protective Glasses



Hearing Protection

Installation in accordance with these instructions and adherence to warnings will ensure compliance with relevant regulatory and safety standards as at the revision date.

Failure to adhere to these instructions may affect the roadworthiness of the vehicle or cause personal injury, death or damage to property.

BY USING THIS PRODUCT YOU ACKNOWLEDGE AND AGREE THAT TO THE EXTENT PERMITTED BY LAW PIAK WILL NOT ACCEPT LEGAL OR OTHER LIABILITY FOR ANY LOSS, INJURY OR DAMAGE CAUSED BY INCORRECT OR INAPPROPRIATE INSTALLATION OR USE OF THE PRODUCT.

TOOLS REQUIRED

- | | | |
|--|--------------------------|--|
| 1. Metric socket and spanners | 5. Marking pen | 9. Test lamp or multi-meter |
| 2. Phillips and flat head screwdrivers | 6. Rust inhibiting paint | 10. Drill and metric drill bits |
| 3. Torx drivers | 7. 2" Masking tape | 11. Soldering iron and electrical tape |
| 4. Torque wrench | 8. Air hacksaw | |

PARTS LIST

⚠ Important : Check contents of fitting kit before commencing fitment and report any discrepancies.

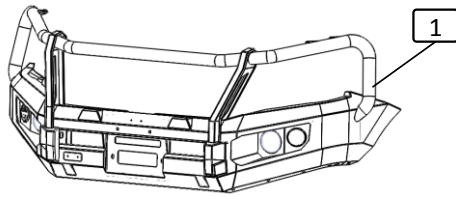
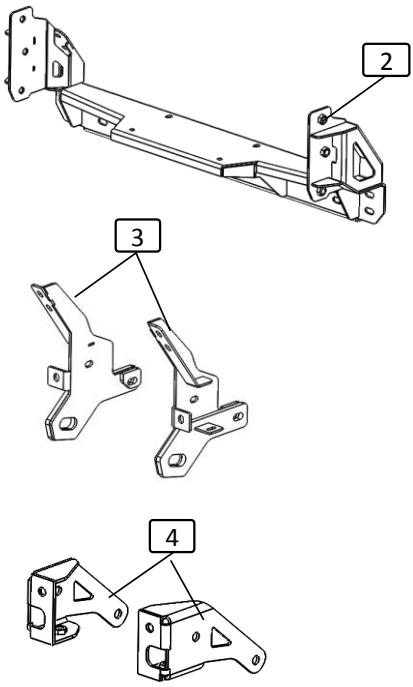
Steel Bull Bar			
Item	Component Name	Q'ty	Remarks
1	Bull Bar	1	
Chassis Mounting Bracket (RH & LH)			
Item	Component Name	Q'ty	Remarks
2	Mounting Bracket	1	
3	Chassis support bracket & Recovery points (RH,LH)	2	
4	Chassis Support Bracket inside (RH,LH)	2	
5	Hex Bolt M12x35x1.5	6	
6	Hex Bolt M12x90x1.25	2	
7	Hex Bolt M12x100x1.25	2	
8	Hex Nut M12x1.25	4	
9	Flat Washer M12	14	
10	Spring Washer M12	10	
11	Hex Bolt M10x35x1.5	9	
12	Hex Bolt M10x30x1.25	8	
13	Flat Washer M10	26	
14	Spring Washer M10	17	
15	Flange Nut M10x1.25	4	
16	Hex Nut M10x1.5	5	
17	Hex Bolt M8x30x1.25	4	
18	Flat Washer M8	8	
19	Spring Washer M8	4	
20	Flange Nut M8x1.25	4	

Protection Plate			
Item	Component Name	Q'ty	Remarks
21	Center Protection Plate	1	
22	Protection Plate (RH,LH)	2	
23	Hex Bolt M10x35x1.5	2	
24	Flat Washer M10	2	
25	Spring Washer M10	2	
26	Hex Bolt M8x30x1.25	2	
27	Spring Washer M8	2	
28	Flat Washer M8	4	
29	Flange Nut M8x1.25	2	
30	Hex Bolt M6x20x1.0	13	
31	Flat Washer M6	13	
32	Spring Washer M6	13	
33	Cage Nut M6x1.0x3T	13	

Plate infilled			
Item	Component Name	Q'ty	Remarks
34	Plate infilled (RH,LH)	1	
35	Hex Bolt M6x20x1.0	4	
36	Spring Washer M6	4	
37	Flat Washer M6	8	
38	Flange Nut M6x1.0	4	

Winch Control Plate			
Item	Component Name	Q'ty	Remarks
39	License Plate Bracket	1	
40	Hex Bolt M6x20x1.0	2	
41	Spring Washer M6	2	
42	Flat Washer M6	4	
43	Flange Nut M6x1.0	2	

License Plate Bracket			
Item	Component Name	Q'ty	Remarks
44	License Plate Bracket (Inner)	1	
45	License Plate Bracket (Outer)	1	
46	Hex Bolt M6x20x1.0	4	
47	Spring Washer M6	4	
48	Flat Washer M6	6	
49	Cage Nut M6x1.0x3T	2	
50	Flange Nut M6x1.0	2	
51	Button Head Bolt M6x20x1.0 sus	2	
52	Flat Washer M6 sus	4	
53	Nylon Washer M6	4	
54	Nyloc Nut M6x1.0	2	

Components Overview

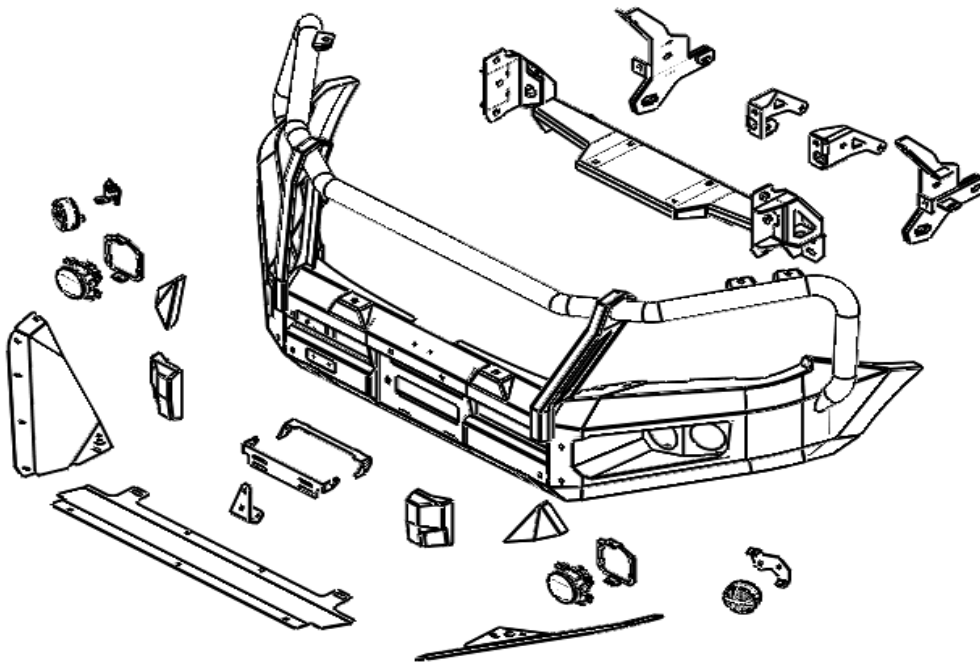

TORQUE SETTING OF FASTENER

Mounting bolts must be tightened to torque's specified following ;

Bolt Diameter (mm.)	Class 8.8		Class 10.9	
	Torque (Nm.)	Torque (ft-lb.)	Torque (Nm.)	Torque (ft-lb.)
M6	10.5	7.7	15	11.1
M8	25.5	18.8	36.5	26.9
M10	50.5	37.2	72.2	53.3
M12	88	64.9	126	92.9
M14	140	103	200	148

FITTING PROCEDURE



- 1 Locate the vehicle in a suitable area.

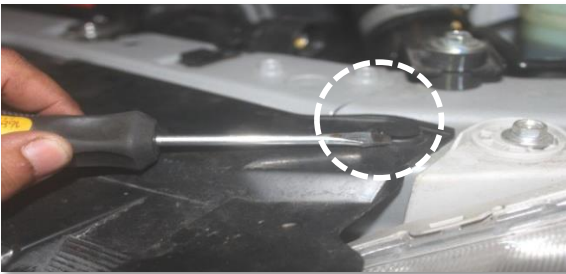

- 2 Remove the clips retaining the top of the grille. Retain for re-fitment.



- 3 Remove the screw in the center of the grille. Retain for re-fitment.



- 4 Unclip the lower grille and carefully remove. Place the grille where it will not be damaged for re-fitment later.

FITTING PROCEDURE



- 5 Remove and retain the clips and screws retaining the top of the bumper.



- 6 If fog lights are fitted disconnect the wiring loom.



- 7 Carefully remove the bumper.



- 8 Remove and retain the front stone tray and front intrusion beam.

FITTING PROCEDURE



- 9 Remove and discard the inner guard retaining brackets.

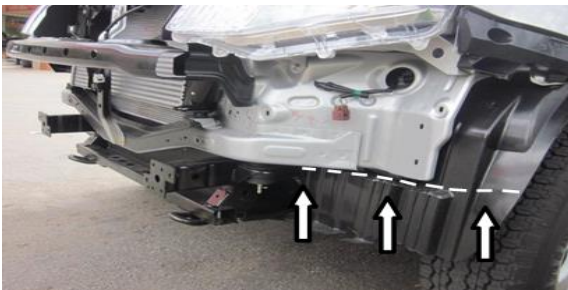

- 10 Trim the inner guard as shown in the picture.

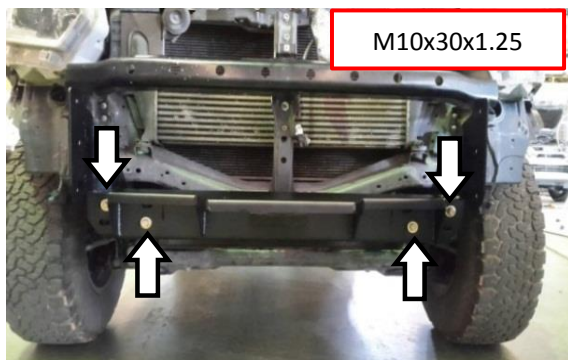

- 11 Lift the chassis mount bracket fit 1 onto the vehicle. Secure with four M10 bolts (M10x30x1.25), spring washers and fl washers as shown.



- 12 Solder the bull bar fog lamp wiring looms to the vehicle fog lamps.

FITTING PROCEDURE



- 13 Place chassis support bracket inside to the chassis mounting bracket as shown.



- 14 Place chassis support bracket outside to the chassis mounting bracket as shown.



- 15 Secure with two M12 bolts (M12x90x1.25), spring washers, flat washers and hex nuts as shown.

FITTING PROCEDURE

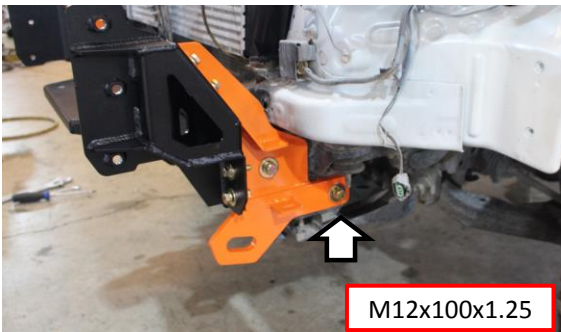

- 16 Secure with two M12 bolts (M12x100x1.25), spring washers, flat washers and hex nuts as shown.

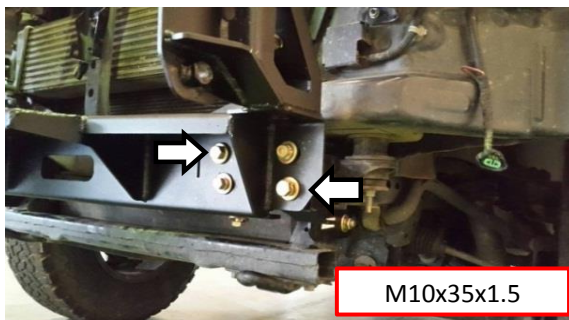

- 17 Secure with two M10 bolts (M10x35x1.5), spring washers and flat washers as shown.

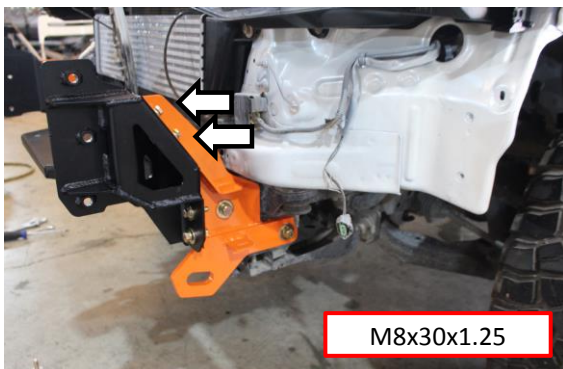

- 18 Secure with two M8 bolts (M8x30x1.25), spring washers, flat washers and flange nuts at top of chassis support bracket outside as shown.

Repeat in step 14-19 for the opposite side.

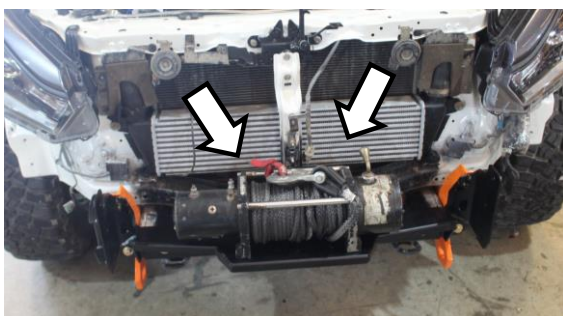

- 19 location of winch on the chassis mount bracket .

FITTING PROCEDURE

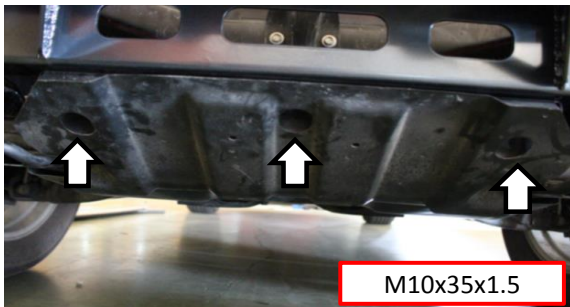

- 20 Refit the front stone tray using the original bolts at the rear and three M10 bolts (M10x35x1.5), flat washers, spring washers and hex nuts to the chassis mount bracket.

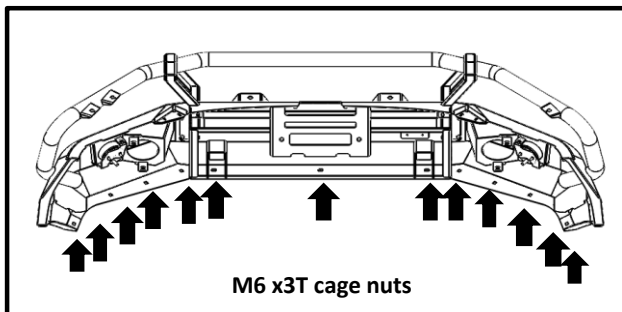

- 21 Insert eleven cage nuts to the bullbar as indicators.



- 22 Lift the bullbar fit to the chassis mount.

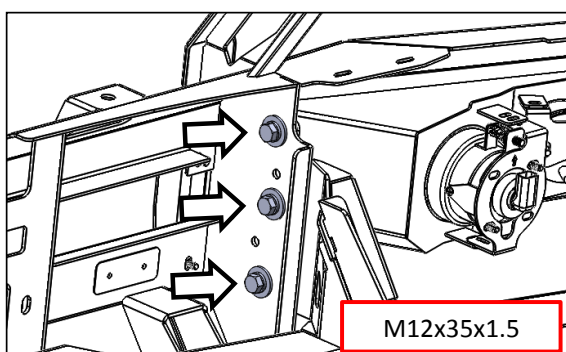

- 23 Secure the mounting bracket to the bullbar by using two M12 bolts (M12x35x1.5), spring washers, flat washers and chassis mount spacers.

FITTING PROCEDURE

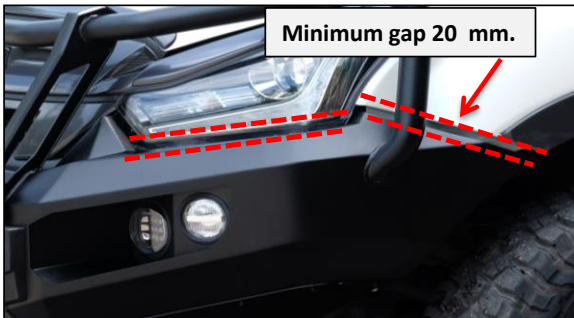

- 24 Align the bar so there is a 20mm gap between the car and wing return of the bar and the end of the wing is in line with the wheel arch.

If the bar does not sit centrally across the front of the vehicle, loosen the chassismount and adjust accordingly.

Tighten all bolts to the correct torque.

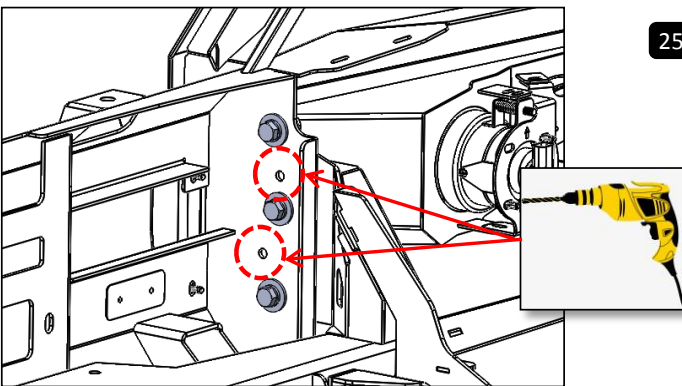

- 25 Drill two 10.5mm holes through the chassis mount bracket by using holes on the bullbar as a guide.

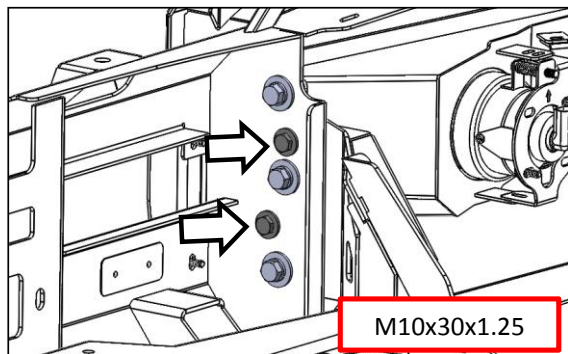

- 26 Secure with two M10 bolts (M10x30x1.25) and flange nuts as shown. Repeat for the opposite side.

Using a LED test lamp or multi meter locate the "Parking Lights" wires. Wires are located behind the headlamp inside the engine bay.

PIAK LED Harness codes

- Indicator Yellow
- Park brown
- Earth White

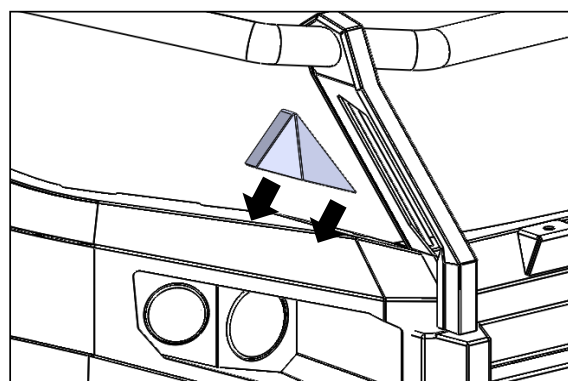

- 27 Place RH Plate infilled to the bullbar.

FITTING PROCEDURE

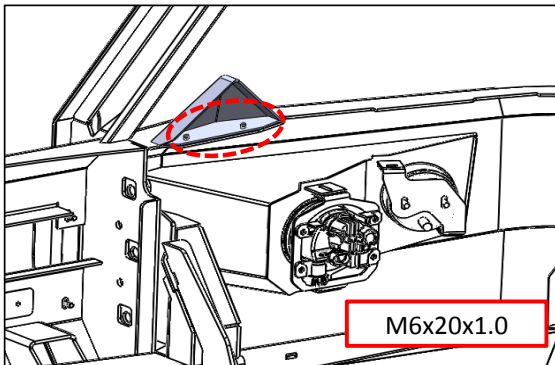

- 28 Secure with two M6 bolts (M6x20x1.0) and flange nuts as shown.

Repeat for the opposite side.

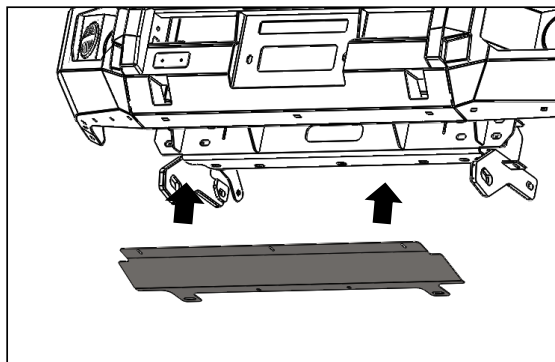

- 29 Fit the center protection plate to the bull bar by using three M6 bolts (M6x20x1.0), spring washers, flat washers and flange nuts.

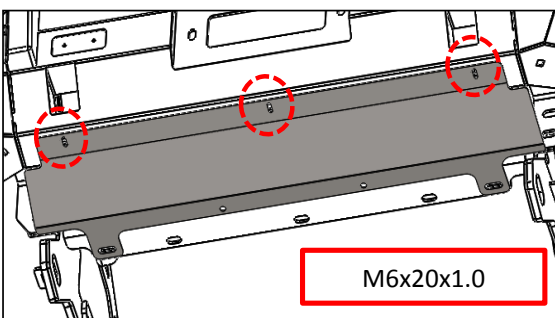

FITTING PROCEDURE

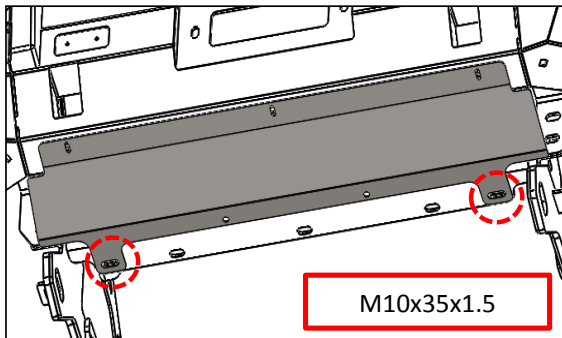

- 30** Secure the center protection plate to the chassis mount by using two M10 bolts (M10x35x1.5), spring washers and flat washers.

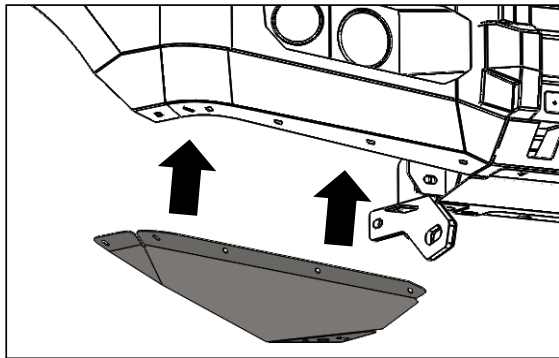

- 31** Fit the outer protection plate to the bull bar

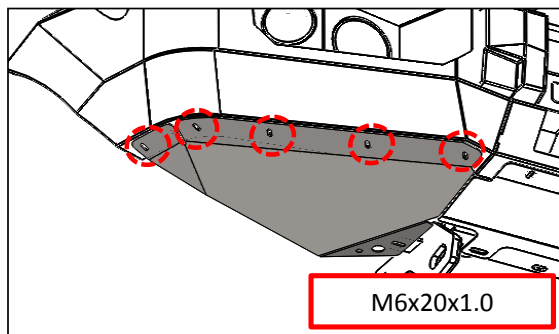

- 32** Using four M6 bolts (M6x20x1.0), spring washers and flat washers.

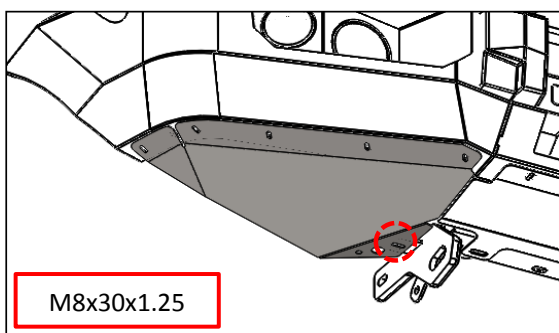

- 33** Secure to the mounting bracket by using a M8 bolt (M8x30x1.25), spring washer, flat washers and flange nut.

Repeat for the opposite side.

FITTING PROCEDURE



34

Re-fit the front grille removed earlier to the vehicle by using four clips and one screw for re-fitment.

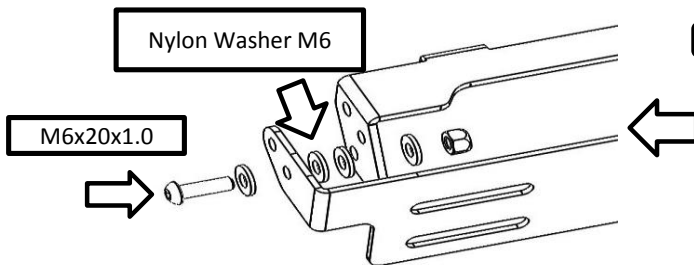

35

Assemble License plate bracket by using two M6 button head, flat washer, Nylon Washer M6 and nyloc nut as shown.

Do not fully tighten.

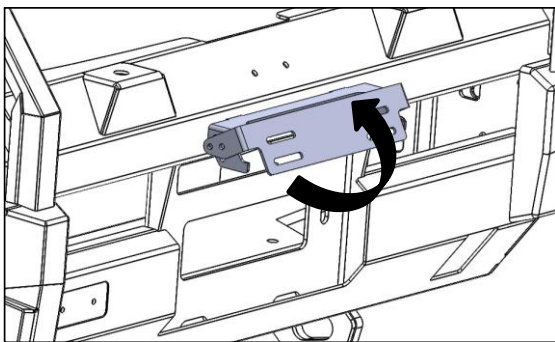

FITTING PROCEDURE

