

# PIAK

## ELITE

## 3-LOOP

## WINCH BAR

## FITTING INSTRUCTIONS



# TOYOTA HILUX REVO 2015-2017

## PK105FG1TH15E

Fitting Time : approx. 3 hours

ELITE 3-LOOP WINCH BAR TOYOTA HILUX REVO 2015-2017  
SD-RD-FT/FB-08  
Rev.01 (23-NOV-2023)

## BULL BAR SAFETY NOTICE:

INSTALLATION SHOULD ONLY BE DONE BY APPROPRIATELY QUALIFIED OR EXPERIENCED PERSONS IN ACCORDANCE WITH THESE INSTRUCTIONS.

IT IS THE RESPONSIBILITY OF THE INSTALLER TO ENSURE THAT THE PRODUCT IS CORRECTLY FITTED.

## WARNING:

Do not attach Vehicle Frontal Protection System (**VFPS**) to the vehicle using anchorages not intended for this purpose. (e.g. engine mounting bolts)

Do not use this product for any vehicle make or model, other than those specified by the VFPS manufacturer.

Do not remove the plaque or label from the VFPS.

Do not modify the structure of the VFPS in any way.

The VFPS has been produced to provide continued functionality of parking sensors and other "driver assist" features as closely as possible to Original Equipment. However, as all possible road conditions and combination of other accessories fitted to the vehicle which may affect functionality characteristics cannot be anticipated, ***the driver remains responsible at all times for properly controlling the vehicle, monitoring all "driver assist" features and intervening where required to ensure the vehicle is safely operated.***

## IMPORTANT INFORMATION:

Before installing the VFPS:

Check that all components, as listed in the assembly table, are available.

Thoroughly read all instructions.

This product or its fasteners must not be modified in any way.

These instructions are accurate as at the revision date and do not take into account any changes made by the vehicle manufacturer to vehicle design after the revision date or other accessories that are or have been fitted to the vehicle. Piak cannot be held responsible for such changes and appropriate enquiries should be made before installation.

Before installing, inspecting and/or maintaining the VFPS, the work space should be safe and clear of fuel, debris, electrical or other components.

During installation:

It is the responsibility of the installer to confirm correct operation/clearance of all components.

All holes drilled shall have all burrs and swarf removed then coated with a suitable rust preventative paint.

Ensure that all hardware is fastened to torque list as detailed in these instructions.

## **MAINTENANCE AND CARE:**

To ensure continued safety and correct operation of the product, the VFPS must be routinely inspected and regularly serviced (including bolt torque checked for correct tension) by an appropriately qualified or experienced person.

The high tensile fasteners supplied with this product were used to achieve the specified rating. If replacement of the fasteners is required, fasteners of the same rating and quality must be used.

If this VFPS is fitted with a hinged number plate bracket, extra care must be taken when returning back to public roads following the use of the winch or conducting a deep water crossing.

The driver must ensure that the number plate bracket is returned back to the down position allowing full visibility of the number plate when returning to public roads.

## **EQUIPMENT:**

These safety products should, at a minimum, be used when fitting or working on the product.



Protective Glasses



Hearing Protection

**Installation in accordance with these instructions and adherence to warnings will ensure compliance with relevant regulatory and safety standards as at the revision date.**

**Failure to adhere to these instructions may affect the roadworthiness of the vehicle or cause personal injury, death or damage to property.**

**BY USING THIS PRODUCT YOU ACKNOWLEDGE AND AGREE THAT TO THE EXTENT PERMITTED BY LAW PIAK WILL NOT ACCEPT LEGAL OR OTHER LIABILITY FOR ANY LOSS, INJURY OR DAMAGE CAUSED BY INCORRECT OR INAPPROPRIATE INSTALLATION OR USE OF THE PRODUCT.**

## TOOLS REQUIRED

1. Metric socket and spanners
2. Phillips and flat head screw driver
3. Torque wrench
4. Marking pen
5. 2" Masking tape
6. Drill and metric drill bits
7. Test lamp or multi-meter

## PARTS LIST

**⚠ Important :** Check contents of fitting kit before commencing fitment and report any discrepancies.

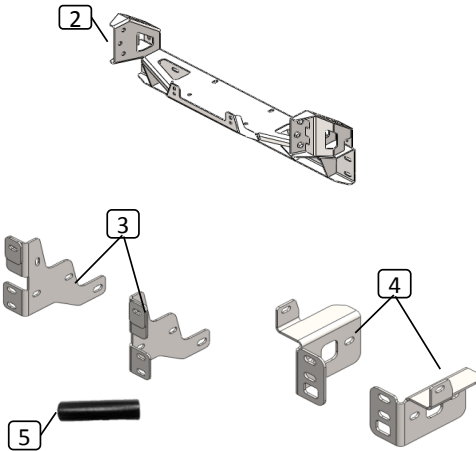
Steel Bull bar			
Item	Component Name	Q'ty	Remarks
1	Winch Bull Bar	1	
Chassis Mounts to Vehicle			
Item	Component Name	Q'ty	Remarks
2	Chassis mounting bracket (R/L)	1	
3	Outer mounting support bracket (R/L)	2	
4	Inner mounting support bracket (R/L)	2	
5	Crush tube 16x55 mm.	4	
6	Hex Bolt M12x35x1.25	2	
7	Hex Bolt M12x35x1.5	6	
8	Spring Washer M12	8	
9	Flat Washer M12	14	
10	Hex Nut M12x1.5	6	
11	Hex Bolt M10x90x1.5	4	
12	Hex Bolt M10x35x1.5	6	
13	Hex Bolt M10x35x1.25	4	
14	Spring Washer M10	14	
15	Flat Washer M10	20	
16	Hex Nut M10x1.5	10	
17	Hex Bolt M8x30x1.25	2	
18	Spring Washer M8	2	
19	Flat Washer M8	4	
20	Flange Nut M8x1.25	2	

Protection Plates to Bar			
Item	Component Name	Q'ty	Remarks
21	Center Protection Plate	1	
22	Outer Protection Plate RH	1	
23	Outer Protection Plate LH	1	
24	Hex Bolt M6x20x1.0	21	
25	Spring Washer M6	21	
26	Flat Washer M6	21	
27	Cage Nut M6x1.0x3T	21	
Front Grill Bracket			
Item	Component Name	Q'ty	Remarks
28	Front Grill Bracket	2	
29	Hex Bolt M6x20x1.0	2	
30	Spring Washer M6	2	
31	Flat Washer M6	4	
32	Flange Nut M6x1.0	2	
Winch Control Plate			
Item	Component Name	Q'ty	Remarks
33	Winch Control Plate	1	
34	Hex Bolt M6x20x1.0	2	
35	Spring Washer M6	2	
36	Flat Washer M6	2	
37	Flange Nut M6x1.0	2	
License Plate Bracket			
Item	Component Name	Q'ty	Remarks
38	License Plate Bracket (Inner)	1	
39	License Plate Bracket (Outer)	1	
40	Hex Bolt M6x20x1.0	4	
41	Spring Washer M6	4	
42	Flat Washer M6	6	
43	Cage Nut M6x1.0x3T	2	
44	Flange Nut M6x1.0	2	
45	Button Head Bolt M6x20x1.0	2	
46	Flat Washer M6 (OD=14)	2	
47	Nylon Washer M6	4	
48	Nyloc Nut M6x1.0	2	

Inner Guard Bracket			
Item	Component Name	Q'ty	Remarks
49	Inner Guard Bracket	2	
50	Hex Bolt M6x20x1.0	4	
51	Spring Washer M6	4	
52	Flat Washer M6	8	
53	Flange Nut M6x1.0	4	
54	Hex Bolt M8x25x1.25	4	
55	Spring Washer M8	4	
56	Flat Washer M8	8	
57	Flange Nut M8x1.25	4	

## Components Overview

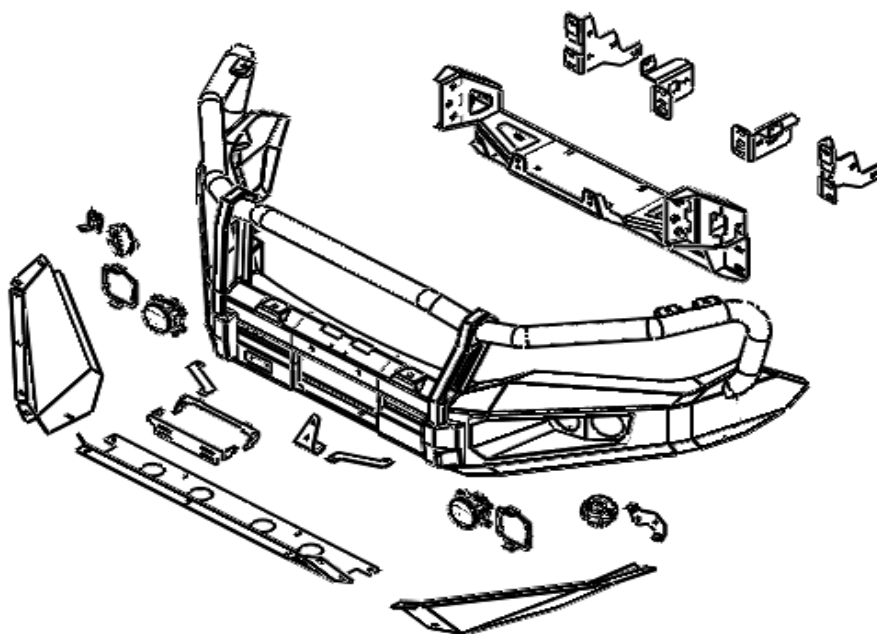

## TORQUE SETTING OF FASTENER

Mounting bolts must be tightened to torque's specified following ;

Bolt Diameter (mm.)	Class 8.8		Class 10.9	
	Torque (Nm.)	Torque (ft-lb.)	Torque (Nm.)	Torque (ft-lb.)
M6	10.5	7.7	15	11.1
M8	25.5	18.8	36.5	26.9
M10	50.5	37.2	72.2	53.3
M12	88	64.9	126	92.9
M14	140	103	200	148

## FITTING PROCEDURE



- 1 Locate the vehicle in a suitable position.
- 2 Rest the bullbar on a surface that will not scratch the bar.

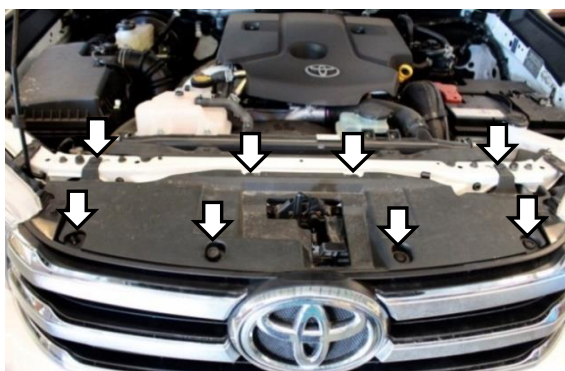

- 3 Remove the clips and the bonnet that retain the grille at the top. Keep for re-fitment of grille.



- 4 Remove the clips that retain the grille. Keep for re-fitment of grille.



- 5 Remove and keep the original bolt either side that retain the grille.

Repeat for the opposite side.

## FITTING PROCEDURE

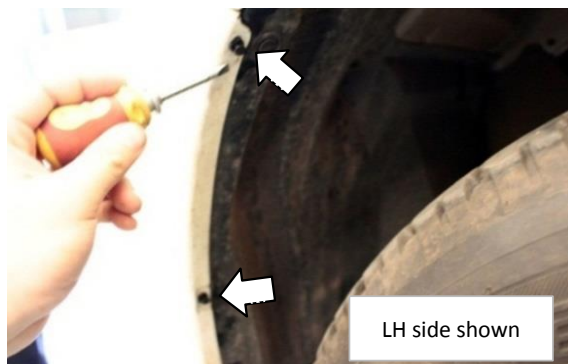

**6** Remove and discard the screws retaining the bumper bar in the wheel arch.

**7** Repeat for the opposite side.

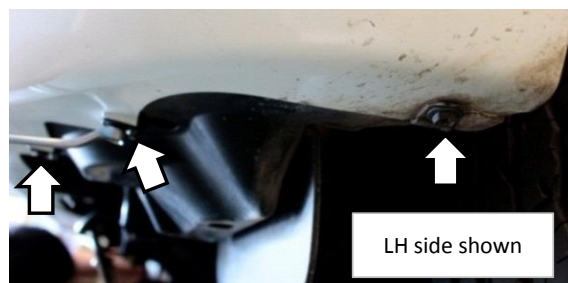

**8** Remove and discard the plastic clips and bolts from the lower section of the bumper bar as indicators.

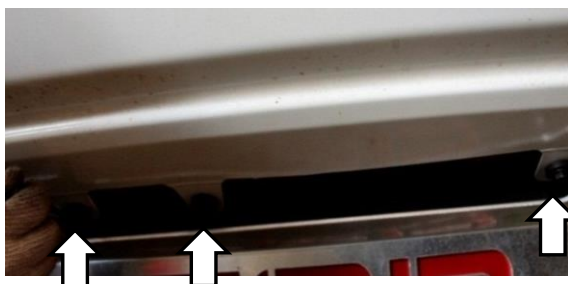

**9** Carefully remove the bumper from the vehicle.

If unsure about bumper removal refer to the workshop manual.



**10** Remove and discard the upper air guides from both sides of the vehicle.

**11** Repeat for the opposite side.





## FITTING PROCEDURE

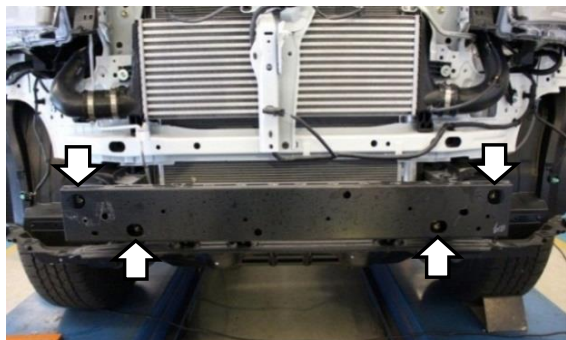

- 12** Remove and discard the front intrusion beam.



- 13** Remove and discard the outer bumper clips from the front guards.

- 14** Repeat for the opposite side.

- 15** Fit the inner guard retaining bracket to the vehicle using two (M8 x 25mm) hex bolts, M8 spring and flat washers and M8 flange nuts.

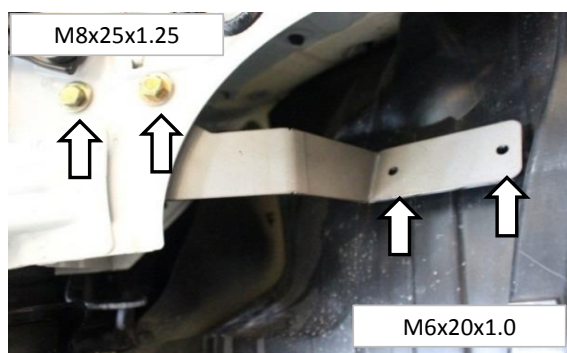

- 16** Using the bracket as a guide drill two holes using a 6.5mm drill bit.

- 17** Secure the inner guard to the inner guard bracket with two (M6 x 20mm) bolts, spring washers, flat washers and nuts.

- 18** Repeat for the opposite side.

- 19** Lift the chassis mounting bracket onto the chassis of vehicle.



## FITTING PROCEDURE



- 20** Secure with four M10 bolts (M10x35x1.25), spring and flat washers as indicator.



- 21** Place the inner mounting support bracket at the rear of mounting bracket.

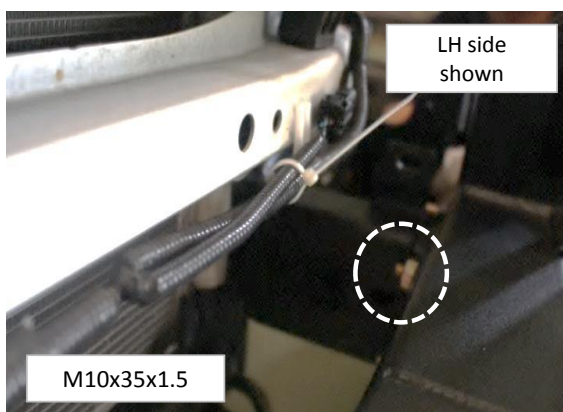

- 22** Secure with M10 bolt (M10x35x1.5), spring and flat washers and hex nut as shown at the circle.

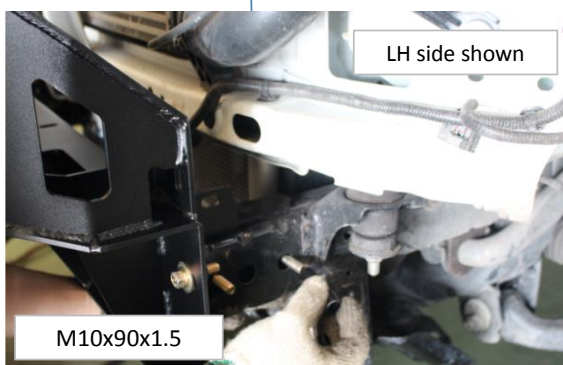

- 23** Place two M10 bolts (M10x90x1.5), spring washers into the inner mounting support bracket and fit into the mounting bracket of vehicle.

- 24** Insert two crush tubes into M10 bolts (M10x90x1.5) fitted to the chassis.

## FITTING PROCEDURE



- 25** Place outer mounting bracket to mounting bracket as shown.

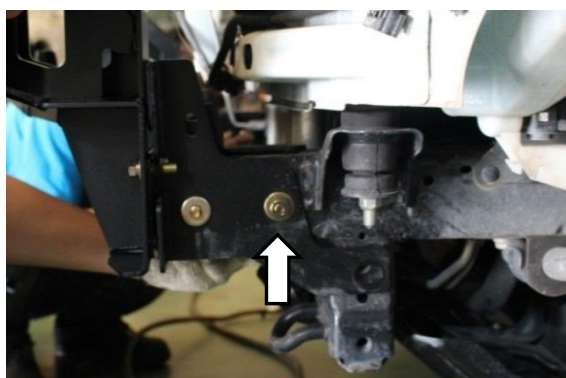

- 26** Secure with M10 flat washer and hex nut.

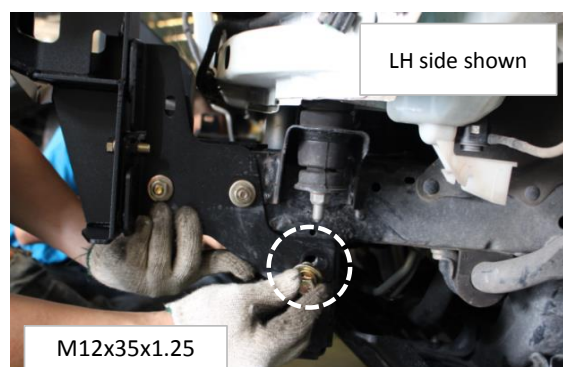

- 27** Secure the outer mounting bracket to chassis of vehicle by using M12 bolt (M12x35x1.25), spring washer and flat washers as shown at the circle.

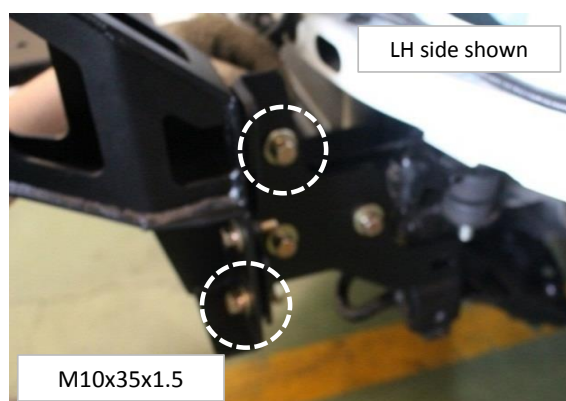

- 28** Secure the outer mounting bracket to mounting bracket by using two M10 bolts (M10x35x1.5), spring and flat washers and hex nuts as shown at the circle.

## FITTING PROCEDURE

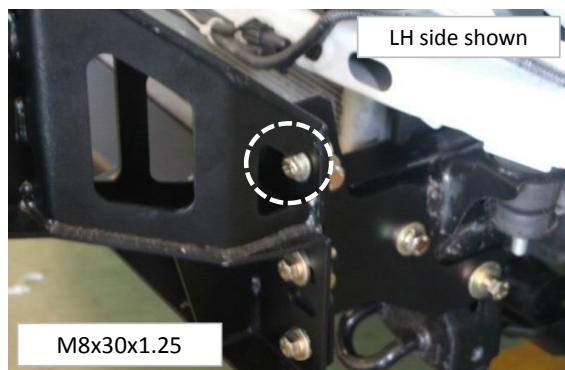

- 29** Secure with M8 bolt (M8x30x1.25), spring washer, flat washer and flange nut as shown.



- 30** Repeat in step 21-29 for RH side.

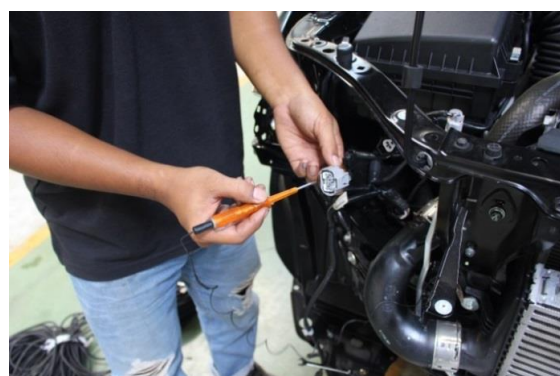

- 31** Using a LED test lamp or multi meter locate the "indicators & Parking Lights" wires. Wires are located behind the headlamp inside the engine bay.

**\*\*\*Repeat for the opposite side**

### PIAK LED Harness codes

- Indicator Yellow
- Park brown
- Earth White

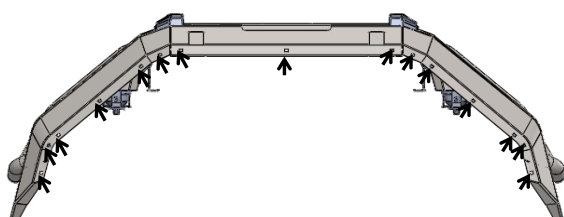

- 32** Insert fifteen M6 cage nuts (3 mm.) onto the bullbar as indicators.

## FITTING PROCEDURE

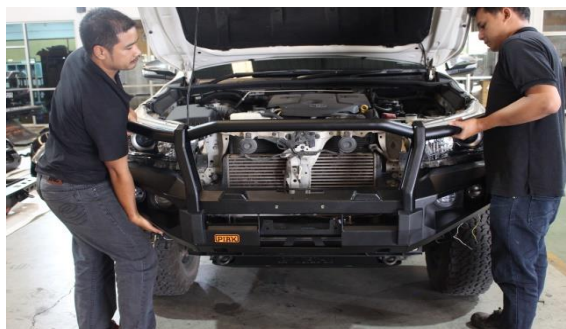

- 33** Lift the bullbar onto the chassis of the vehicle.

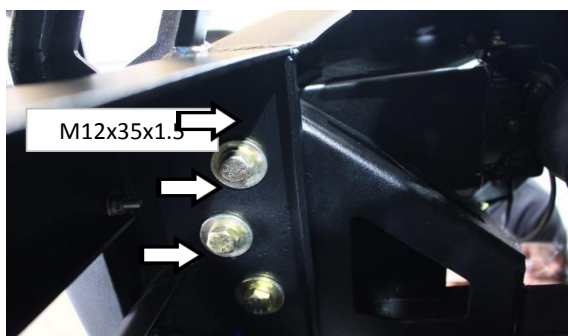

- 34** Secure the bullbar to the mounting bracket by using three M12 bolts (M12x35x1.5), spring washers, flat washers and hex nuts.

**Repeat for the opposite side.**

- 35** Connect cable Fog light and PIAK combination lamp.

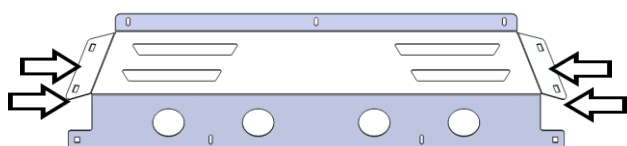

- 36** Insert four M6 cage nuts into the center protection plate as indicators.

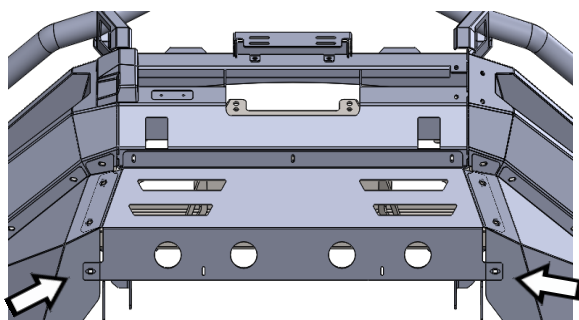

- 37** Secure the center protection plate to the bullbar by using three M6 bolts (M6x20x1.0), spring washers and flat washers.

## FITTING PROCEDURE



- 38** Place LH protection plate onto the bullbar and secure with eight M6 bolts (M6x20x1.0), spring washers and flat washers as indicators.

**Repeat for the opposite side.**

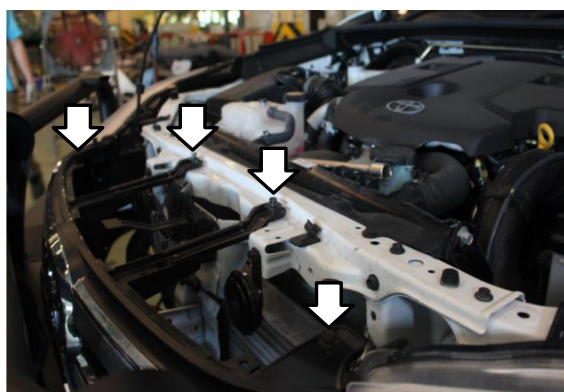

- 39** Re-install the front grill removed earlier to the vehicle by using four original bolts.



- 40** Secure front grill bracket onto the vehicle by using original bolt removed earlier.

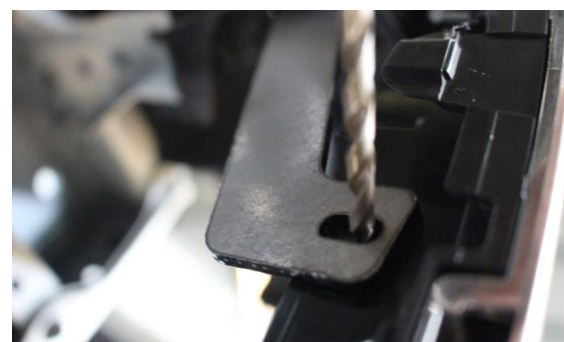

- 41** Drill front grill by using template on the brack as a guide to fit the another side of front grill bracket to the front grill.

Secure by using M6 bolt (M6x20x1.0), spring washer, flat washers and flange nut.

**Repeat for the opposite side.**

## FITTING PROCEDURE



- 42** Re-install the bonnet that retain the grille at the top by using eight clips that removed earlier.

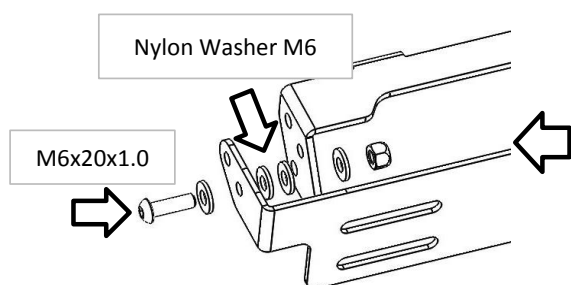

- 43** Assemble License plate bracket by using two M6 button head, flat washer, Nylon Washer M6 and nyloc nut as shown.  
Do not fully tighten.

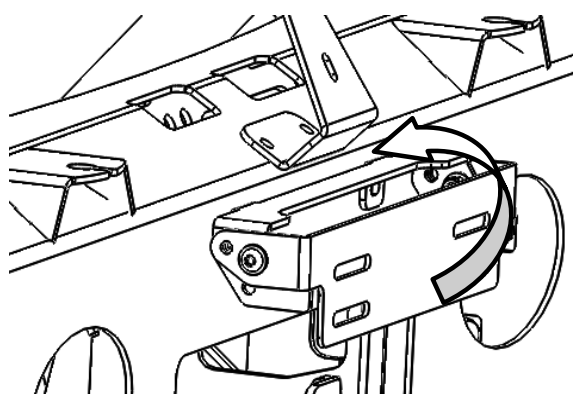

- 44** Secure the license plate to the bracket and place to the bar by using the supplied M6 bolt kits.

## FITTING PROCEDURE

