



PIAK GENESIS BAR WINCH BAR

FITTING INSTRUCTIONS



FORD RANGER 2022

FORD EVEREST 2022

PK106FR22G/FE22G_RBO_URPMB

PK106FR22G/FE22G_RBO_URPMG

PK106FR22G/FE22G_RBO_URPBO

PK106FR22G/FE22G_RMB_URPMB

PK106FR22G/FE22G_RMB_URPMG

PK106FR22G/FE22G_RMB_URPBO

Fitting Time : approx. 3 hours



BULL BAR SAFETY NOTICE:

INSTALLATION SHOULD ONLY BE DONE BY APPROPRIATELY QUALIFIED OR EXPERIENCED PERSONS
IN ACCORDANCE WITH THESE INSTRUCTIONS.

IT IS THE RESPONSIBILITY OF THE INSTALLER TO ENSURE THAT THE PRODUCT IS CORRECTLY FITTED.

WARNING:

Do not attach Vehicle Frontal Protection System (**VFPS**) to the vehicle using anchorages not intended for this purpose. (e.g. engine mounting bolts)

Do not use this product for any vehicle make or model, other than those specified by the VFPS manufacturer.

Do not remove the plaque or label from the VFPS.

Do not modify the structure of the VFPS in any way.

The VFPS has been produced to provide continued functionality of parking sensors and other "driver assist" features as closely as possible to Original Equipment. However, as all possible road conditions and combination of other accessories fitted to the vehicle which may affect functionality characteristics cannot be anticipated, ***the driver remains responsible at all times for properly controlling the vehicle, monitoring all "driver assist" features and intervening where required to ensure the vehicle is safely operated.***

IMPORTANT INFORMATION:

Before installing the VFPS:

Check that all components, as listed in the assembly table, are available.

Thoroughly read all instructions.

This product or its fasteners must not be modified in any way.

These instructions are accurate as at the revision date and do not take into account any changes made by the vehicle manufacturer to vehicle design after the revision date or other accessories that are or have been fitted to the vehicle. Piak cannot be held responsible for such changes and appropriate enquiries should be made before installation.

Before installing, inspecting and/or maintaining the VFPS, the work space should be safe and clear of fuel, debris, electrical or other components.

During installation:

It is the responsibility of the installer to confirm correct operation/clearance of all components.

All holes drilled shall have all burrs and swarf removed then coated with a suitable rust preventative paint.

Ensure that all hardware is fastened to torque list as detailed in these instructions.

MAINTENANCE AND CARE:

To ensure continued safety and correct operation of the product, the VFPS must be routinely inspected and regularly serviced (including bolt torque checked for correct tension) by an appropriately qualified or experienced person.

The high tensile fasteners supplied with this product were used to achieve the specified rating. If replacement of the fasteners is required, fasteners of the same rating and quality must be used.

If this VFPS is fitted with a hinged number plate bracket, extra care must be taken when returning back to public roads following the use of the winch or conducting a deep water crossing.

The driver must ensure that the number plate bracket is returned back to the down position allowing full visibility of the number plate when returning to public roads.

EQUIPMENT:

These safety products should, at a minimum, be used when fitting or working on the product.



Protective Glasses



Hearing Protection

Installation in accordance with these instructions and adherence to warnings will ensure compliance with relevant regulatory and safety standards as at the revision date.

Failure to adhere to these instructions may affect the roadworthiness of the vehicle or cause personal injury, death or damage to property.

BY USING THIS PRODUCT YOU ACKNOWLEDGE AND AGREE THAT TO THE EXTENT PERMITTED BY LAW PIAK WILL NOT ACCEPT LEGAL OR OTHER LIABILITY FOR ANY LOSS, INJURY OR DAMAGE CAUSED BY INCORRECT OR INAPPROPRIATE INSTALLATION OR USE OF THE PRODUCT.

TOOLS REQUIRED

- | | | |
|--------------------------------|--------------------|---------------------------------------|
| 1. Metric Socket and Spanners | 2. 2" Masking tape | 3. Marking pen |
| 4. Drill and metric drill bits | 5. Torque wrench | 6. Phillip and flat head screw driver |

PARTS LIST







Important : Check contents of fitting kit before commencing fitment and report any discrepancies.

Steel Bull Bar			
Item	Component Name	Q'ty	Remarks
1	PIAK Genesis Bar	1	
Mounting Bracket			
Item	Component Name	Q'ty	Remarks
2	Mounting Bracket Center	1	
3	Mounting Bracket (RH)	1	
4	Mounting Bracket (LH)	1	
5	Recovery Point & Support Bracket outside (RH)	1	
6	Recovery Point & Support Bracket outside (LH)	1	
7	Support Bracket Inside (RH)	1	
8	Support Bracket Inside (LH)	1	
9	Shim plate 2.0 mm.	2	
10	Support Bracket (RH)	1	
11	Support Bracket (LH)	1	
12	Plate Nut M10 x 1.5P	4	
13	Wing Bracket (RH)	1	
14	Wing Bracket (LH)	1	
15	Hex Bolt M8x30x1.25	10	
16	Spring Washer M8	10	
17	Flat Washer M8	14	
18	Flange Nut M8x1.25	4	
19	Hex Bolt M10x35x1.5	12	
20	Spring Washer M10	26	
21	Flat Washer M10	40	
22	Flat Washer M10 OD20	8	

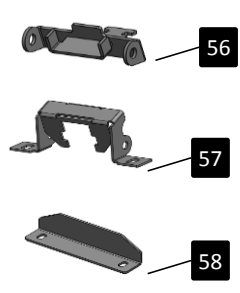
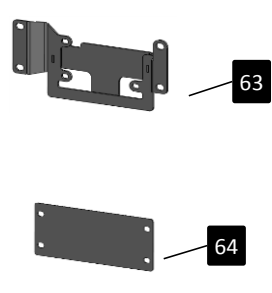
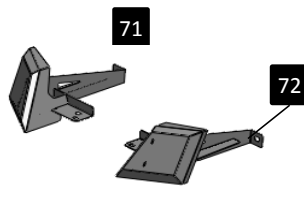
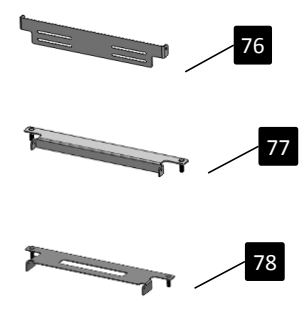
Mounting Bracket			
Item	Component Name	Q'ty	Remarks
23	Hex Nut M10x1.5	12	
24	Hex Bolt M10x35x1.5 Gr10.9	10	
25	Hex Bolt M10x40x1.5 Gr10.9	4	
26	Hex Nut M10x1.5 Gr10.9	10	
27	Hex Bolt M12x60x1.75 Gr10.9 EDP	4	
28	Hex Bolt M12x50x1.5 Gr10.9 EDP	4	
29	Spring Washer M12 EDP	8	
30	Flat Washer M12 OD33 EDP	12	
31	Hex Nut M12x1.5 Gr10.9 EDP	4	
32	Hex Bolt M12x35x1.5 Gr10.9	6	
33	Spring Washer M12	6	
34	Flat Washer M12 OD33	12	
35	Hex Nut M12x1.5 Gr10.9	6	

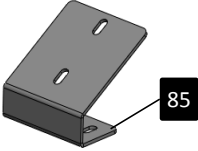
Protection Plate			
Item	Component Name	Q'ty	Remarks
36	Protection Plate Bracket	2	
37	Top Protection Plate center	1	
38	bottom Protection Plate center	1	
39	Side Protection Plate (RH)	1	
40	Side Protection Plate (LH)	1	
41	Hex Bolt M10x35x1.5	3	
42	Spring Washer M10	5	
43	Flat Washer M10	3	
44	Hex Bolt M10x30x1.5	2	
45	Flat Washer M10	4	
46	Hex Nut M10x1.5	2	
47	Hex Bolt M8x25x1.25	12	
48	Spring Washer M8	12	
49	Flat Washer M8	16	
50	Flange Nut M8x1.25	8	
51	Cage Nut M8x1.25x3.2T	8	
52	Hex Bolt M6x20x1.0	10	
53	Spring Washer M6	10	
54	Flat Washer M6	10	
55	Cage Nut M6x1.0x3T	10	

Camera Bracket			
Item	Component Name	Q'ty	Remarks
56	Camera Bracket A	1	
57	Camera Bracket B	1	
58	Camera Cover	1	
59	Button Head Bolt M5x12x0.8	4	
60	Spring Washer M5	4	
61	Flat Washer M5	8	
62	Hex Nut M5x0.8	4	
Adaptive cruise bracket			
Item	Component Name	Q'ty	Remarks
63	Radar Bracket	1	
64	Acrylic Plate	1	
65	Hex Bolt M6x20x1.0	3	
66	Spring Washer M6	3	
67	Flat Washer M6 OD14	6	
68	Flat Washer M6	6	
69	Flange Nut M6x1.0	7	
Infill FR22/FE22			
Item	Component Name	Q'ty	Remarks
70	Infill (RH)	1	
71	Infill (LH)	1	
72	Hex Bolt M6x20x1.0	4	
73	Spring Washer M6	4	
74	Flat Washer M6	8	
75	Flange Nut M6x1.0	4	
License Plate Bracket			
Item	Component Name	Q'ty	Remarks
76	License Plate Bracket (Outer)	1	
77	License Plate Bracket	1	
78	License Plate Bracket C	1	
79	Flat Washer M8	2	
80	Flange Nut M8x1.25	2	
81	Button Head Bolt M6x20x1.0	2	
82	Nyloc Nut M6x1.0	2	
83	Nylon Washer M6	4	
84	Flat Washer M6	4	

Winch Control Plate			
Item	Component Name	Q'ty	Remarks
85	Winch Control Plate	1	
86	Hex Bolt M6x20x1.0	2	
87	Spring Washer M6	2	
88	Flat Washer M6	4	
89	Flange Nut M6x1.0	2	
Accessories			
Item	Component Name	Q'ty	Remarks
90	Sensor Housing	6	  
91	Sensor blanking plugs	6	
92	Cable Tie	15	

Components Overview

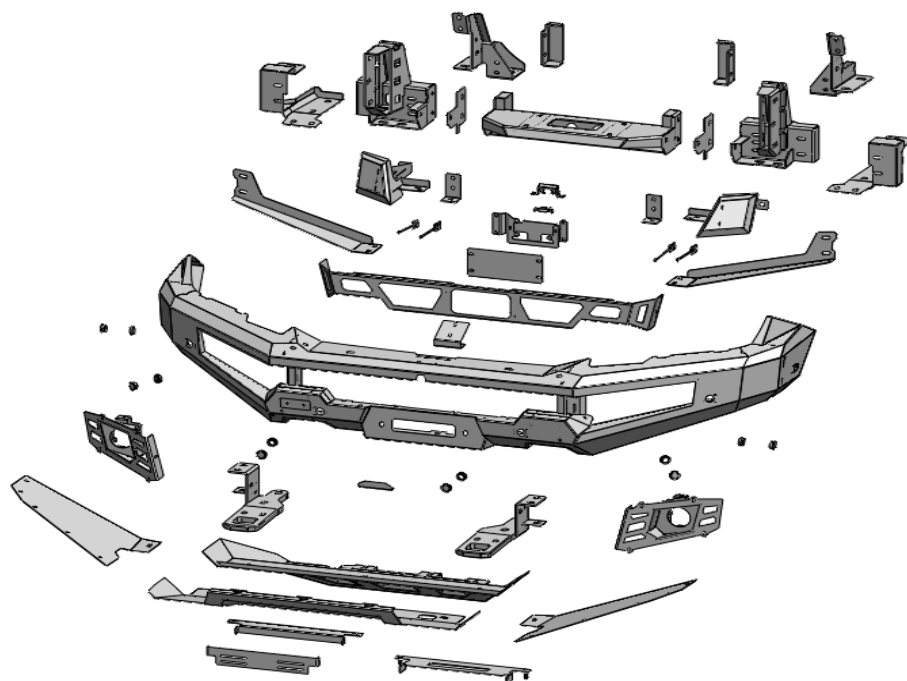

Torque Setting of Fastener

Mounting bolts must be tightened to torque's specified following ;

Bolt Diameter (mm.)	Class 8.8		Class 10.9	
	Torque (Nm.)	Torque (ft-lb.)	Torque (Nm.)	Torque (ft-lb.)
M6	10.5	7.7	15	11.1
M8	25.5	18.8	36.5	26.9
M10	50.5	37.2	72.2	53.3
M12	88	64.9	126	92.9
M14	140	103	200	148

FITTING PROCEDURE



01 Locate the vehicle in a suitable position.



02 Remove OEM Plastic Radiator cover attached to the top of the grille.

***Keep for re-fitment clips and OEM Plastic grille cover.**



03 Remove and keep two bolt that retain the grille at the top as shown.

***Keep for re-fitment of grille.**



04 Remove the water hose to wash the camera. as shown.

Do not disconnect the wiring harness camera .

FITTING PROCEDURE

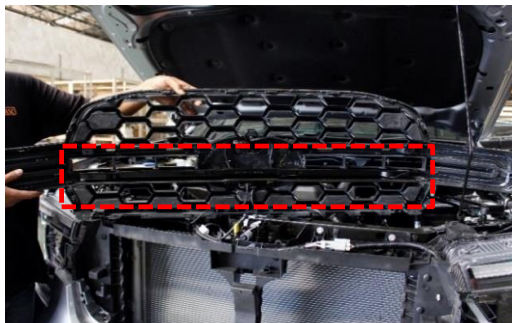

- 05** Remove the grille from vehicle. Flip the back of the grille and remove steel beam. do it carefully

Do not disconnect the wiring harness camera .

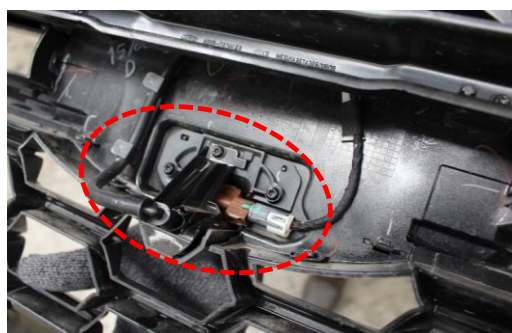

- 06** carefully remove the camera from the grille.

Do not disconnect the wiring harness camera .

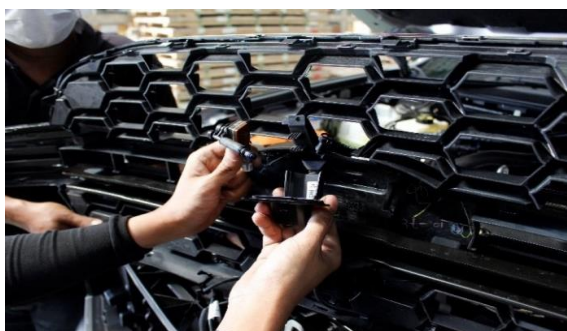

- 07** Remove the grille from vehicle and place on a soft surface.

***Keep for re-fitting of grille.**



FITTING PROCEDURE



- 08** Remove the screws retaining the lower section of the bumper.



- 09** Remove the screws retaining the bumper bar in the wheel arch (Both sides).

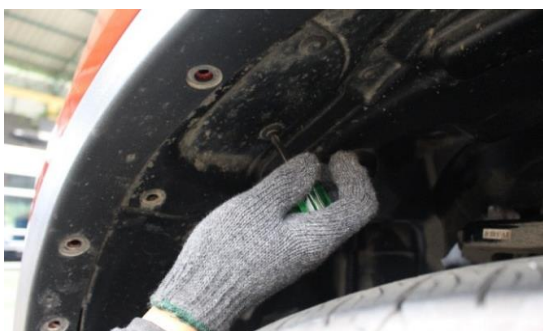

- 10** Unlocked carefully pulled fender flares removal and parking sensor .
Repeat for the opposite side.



FITTING PROCEDURE



- 11** Remove the screws retaining the top section of the bumper.



- 12** Disconnect wiring harness parking sensor and Fog light.



- 13** Carefully remove the bumper from the vehicle.

If unsure about bumper removal refer to the workshop manual.



FITTING PROCEDURE



14 Remove impact foam .as shown.



15 Remove plastic cover Adaptive cruise & Emergency braking.Disconnect wiring harness Adaptive cruise .as shown.



16 Remove impact beam OE.as shown.



17 Remove Adaptive cruise & Emergency braking.as shown.

FITTING PROCEDURE



- 18** Remove the bumper support brackets both sides and chassis mounting bracket of the vehicle, as shown.

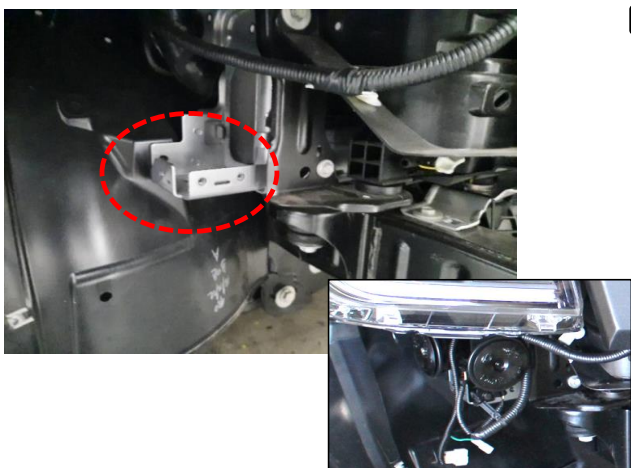

- 19** Right side. move the klaxon from its original position to the top position, as shown.

FITTING PROCEDURE



- 20 Remove the front plastic cover and cut it as shown. re-fitment front plastic cover (A/B) to the vehicle.

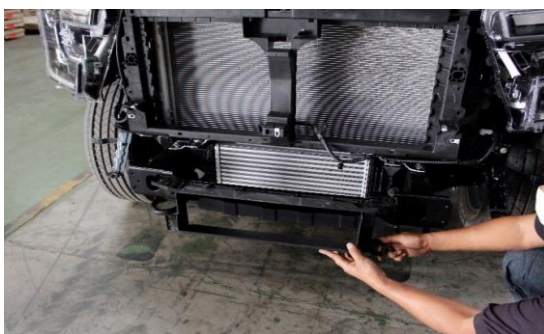

- 21 Remove the below plastic cover. as shown.



- 22 Remove the underbody OE .as shown.



- 23 Remove the Tow hook OE .Watch out for the intercooler dropping down below.

FITTING PROCEDURE

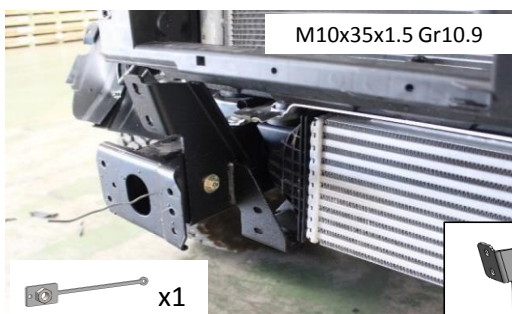

M10x35x1.5 Gr10.9

24

Insert Plate Nut M10 x 1.5P on the hole of the chassis.
Secure the Support Bracket Inside (RH) at location as shown. Secure M10 bolt (M10x35x1.5 Gr10.9), spring washer, flat washer and Plate Nut.

x1

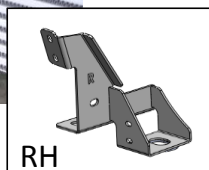

RH



M10x35x1.5 Gr10.9

25

Insert Plate Nut M10 x 1.5P on the hole of the chassis.
Secure the Support Bracket Inside (LH) at location as shown. Secure M10 bolt (M10x35x1.5 Gr10.9), spring washer, flat washer and Plate Nut.

x1



LH

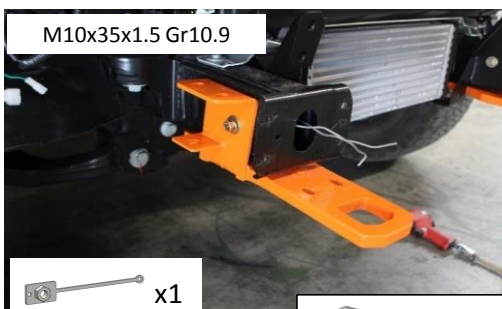

M10x35x1.5 Gr10.9

26

Insert Plate Nut M10 x 1.5P on the hole of the chassis.
Secure the Recovery Point & Support Bracket outside (RH) at location as shown. Secure M10 bolt (M10x35x1.5 Gr10.9), spring washer, flat washer and Plate Nut.

x1

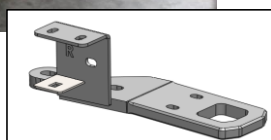

FITTING PROCEDURE



- 27** Insert Plate Nut M10 x 1.5P on the hole of the chassis. Secure the Recovery Point & Support Bracket outside (LH) at location as shown. Secure M10 bolt (M10x35x1.5 Gr10.9), spring washer, flat washer and Plate Nut.

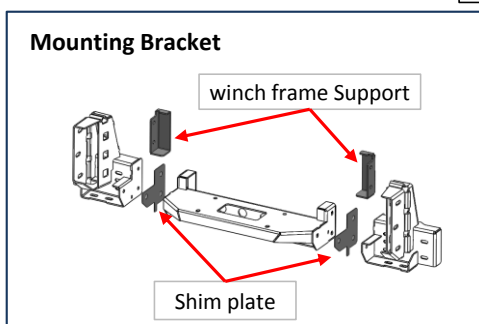
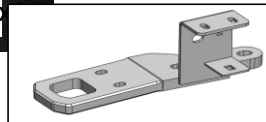

- 28** Assemble Mounting Bracket Center, Mounting Bracket (RH&LH), Shim plate and winch frame Support together.

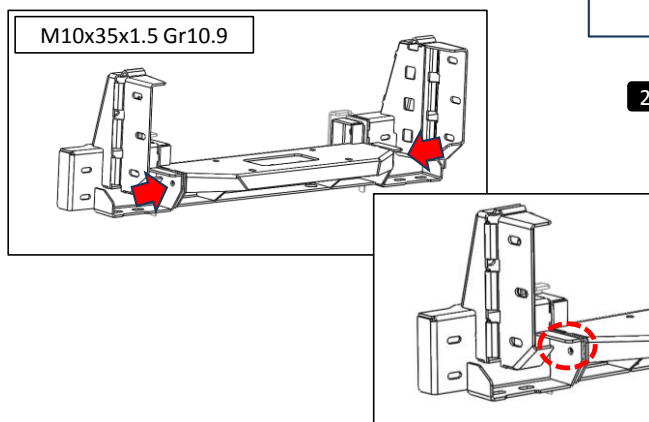
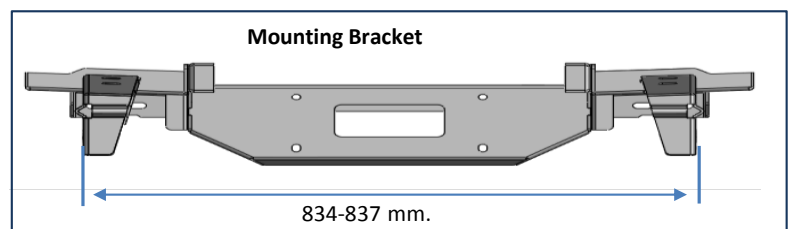

- 29** Using two M10 bolt (M10x35x1.5 Gr10.9), spring washer, flat washer and Hex nut.

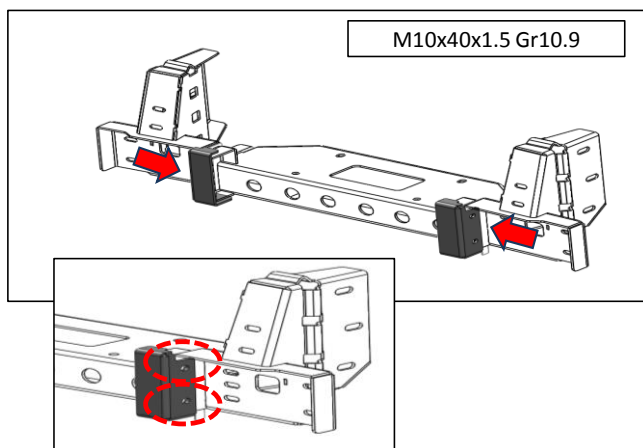

- 30** Using four M10 bolt (M10x40x1.5 Gr10.9), spring washer, flat washer and Hex nut.

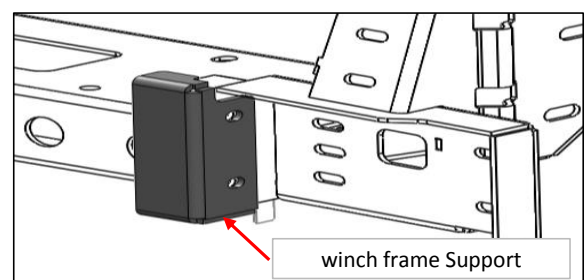

FITTING PROCEDURE



31

Secure Mounting Bracket to the vehicle. Secure three M8 bolt (M8x30x1.25), spring washer, flat washer and Hex nut.

***Repeat for the opposite side.**

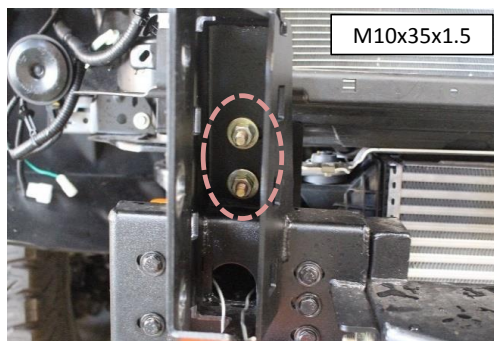

32

Secure the Mounting Bracket to the Support Bracket Inside. Using two M10 bolt (M10x35x1.5), spring washer, flat washer and Hex nut.

***Repeat for the opposite side.**

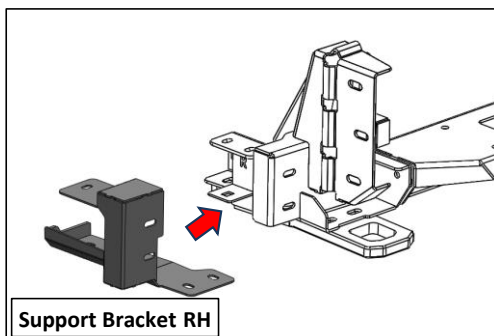

33

Fit the Support Bracket to the Mounting Bracket and Recovery Point

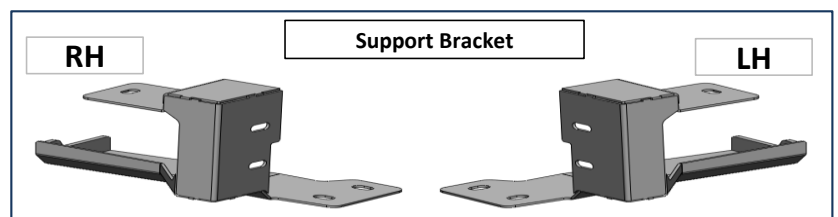

FITTING PROCEDURE

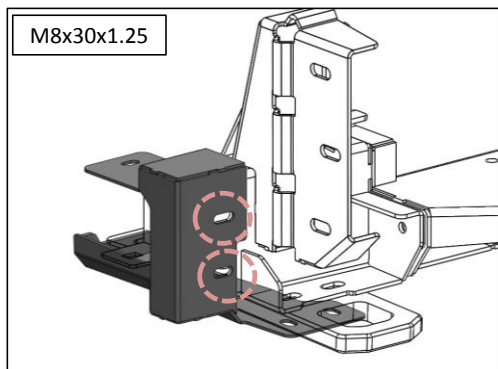

- 34 Using two M8 bolt (M8x30x1.25) , spring washer and flat washer.

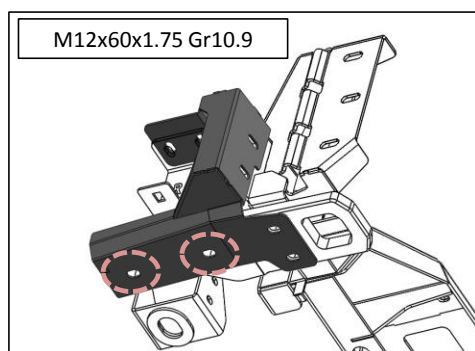

- 35 Using two M12 bolt (M12x60x1.75 Gr10.9) , spring washer and flat washer.

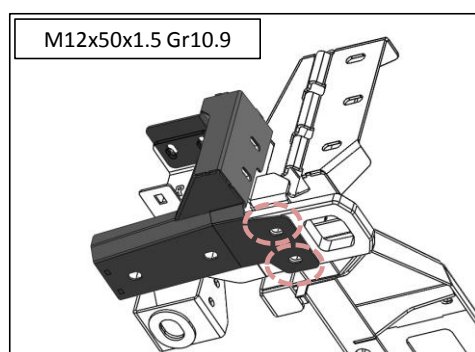

- 36 Using two M10 bolt (M12x50x1.5 Gr10.9), spring washer , flat washer and Hex nut.

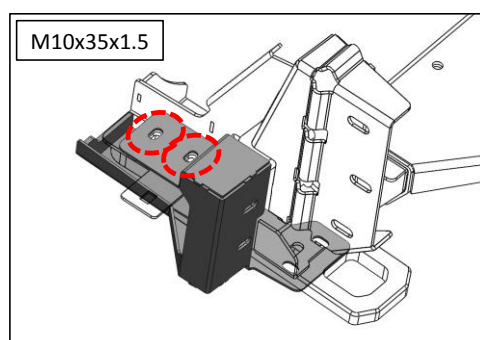

- 37 Using two M10 bolt (M10x35x1.5), spring washer , flat washer and Hex nut.

***Repeat for the opposite side.**

FITTING PROCEDURE



M12x50x1.5 Gr10.9

- 38** Secure the Mounting Bracket to the Recovery Point & Support Bracket outside Using tow M12 bolt (M12x50x1.5 Gr10.9), spring washer , flat washer and Hex nut.

***Repeat for the opposite side.**

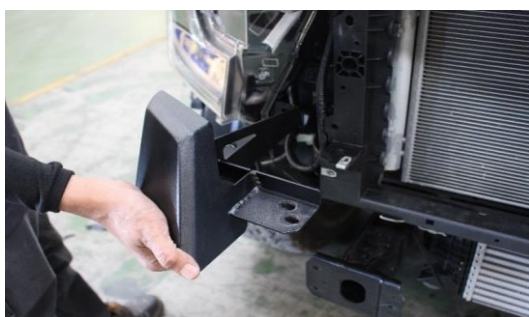

- 39** Secure the Infill to the vehicle.Using bolt OE

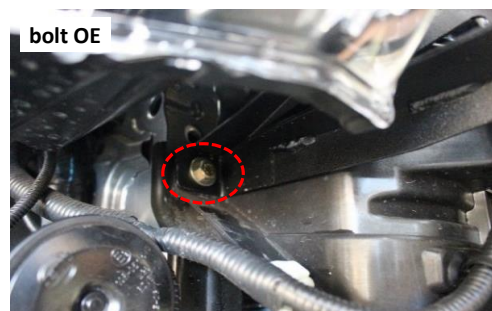

bolt OE

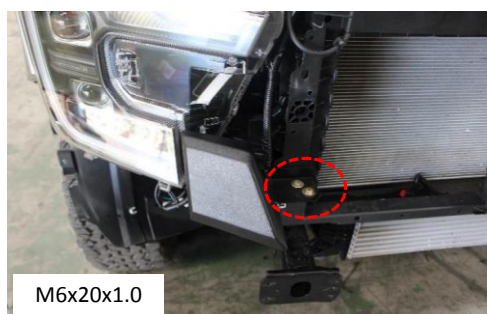

M6x20x1.0

- 40** Using two M6 bolt (M6x20x1.0), spring washer , flat washer and Flange Nut.

***Repeat for the opposite side.**

FITTING PROCEDURE



- 41** Using masking tape, mark a line parallel with top of the bumper to the line cut edge of bumper as a guide to either side. Using a suitable saw carefully cut the flares.

***Repeat for the opposite side.**

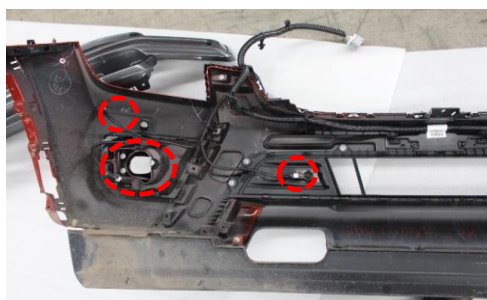

- 42** Remove parking sensor ,Fog light from original bumper and wiring harness .

***Keep for re- fitment of bumper.**

***Do it carefully**

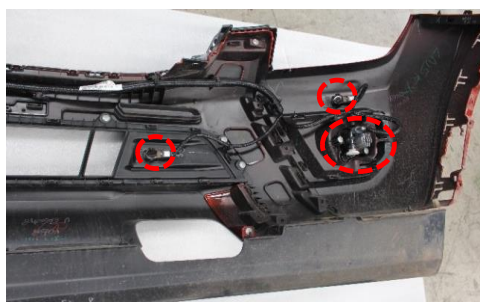

FITTING PROCEDURE

Parking sensor



Fog light 70 mm.



Fog light 90 mm.

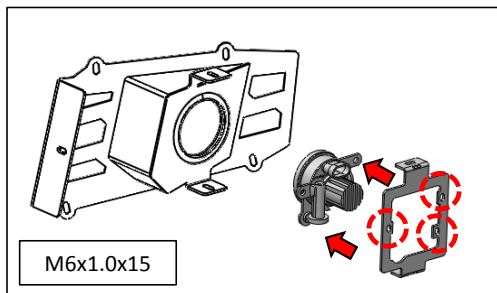

- 43** Fit Fog light on the Fog light Bracket.
Using three M6 bolts (M6x1.0x15) flat washers and flange nuts as shown.

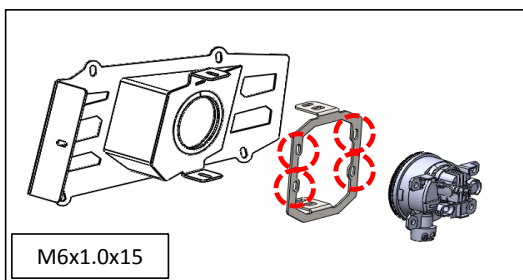

- 44** Fit Fog light 90 mm. on the Fog light Bracket.
Using four M6 bolts (M6x1.0x15) flat washers and flange nuts as shown.

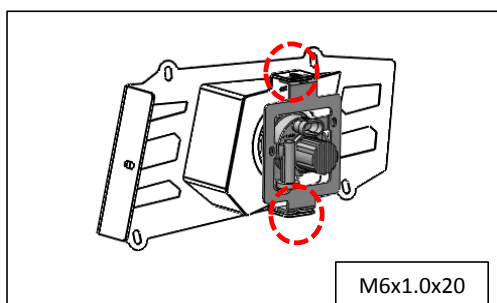

- 45** Fit Fog light on the Fog light Bracket.
on bumper bar and using two M6 (M6x1.0x20) bolts flat washers and flange nut.

FITTING PROCEDURE

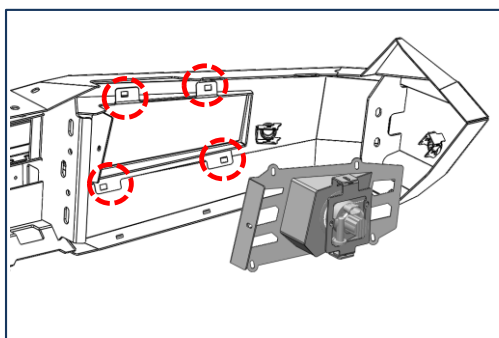

- 46** Insert four M6x1.0x3T cage nuts onto the bumper bar as shown.

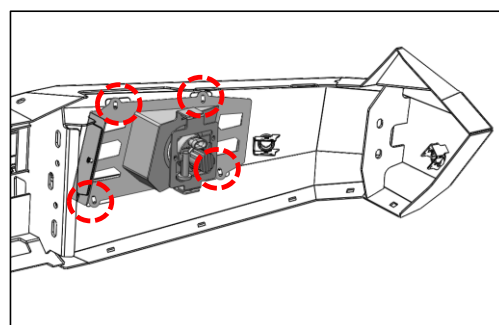

- 47** Fit light frame on the bumper bar using four M6 (M6x1.0x20) bolts flat washers and Spring Washer.

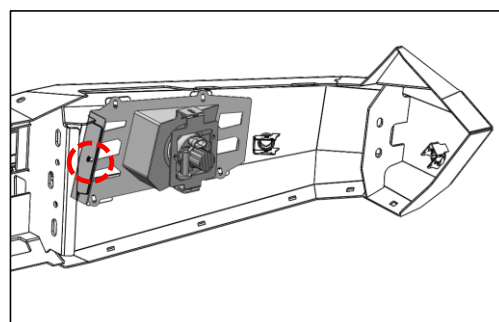

- 48** Using one M6 (M6x1.0x20) bolts flat washers and flange nut.

***Repeat for the opposite side.**

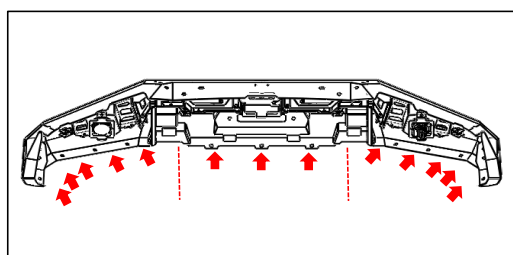

- 49** Insert ten M6x1.0x3T cage nuts onto the bumper bar in side and Insert three M8x1.25x3.2T cage nuts onto the bumper bar in center as shown.

FITTING PROCEDURE

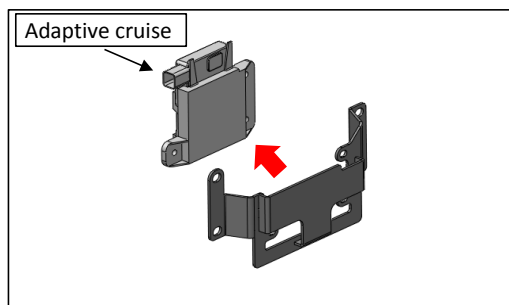

50 Fit Adaptive cruise on the Radarah Bracket.

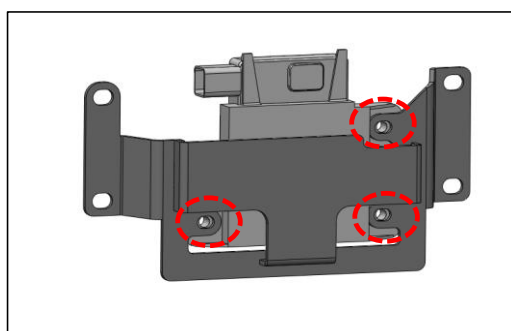

51 Using three M6 bolts (M6x1.0x15) flat washers and flange nuts as shown.

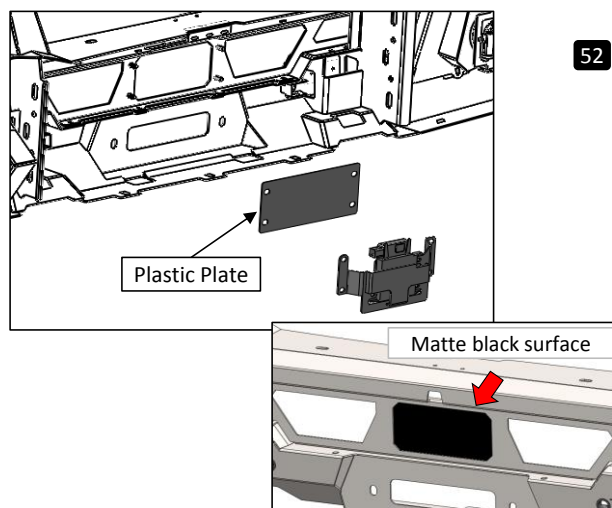

52 Fit Plastic Plate, Adaptive cruise on the bumper bar. Take out the Matte black surface from the front .

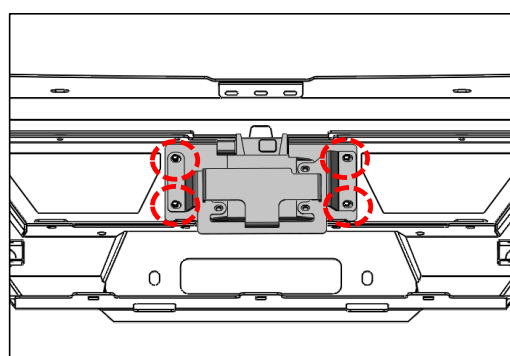

53 Using four M6 nuts and flat washers . as shown.

FITTING PROCEDURE

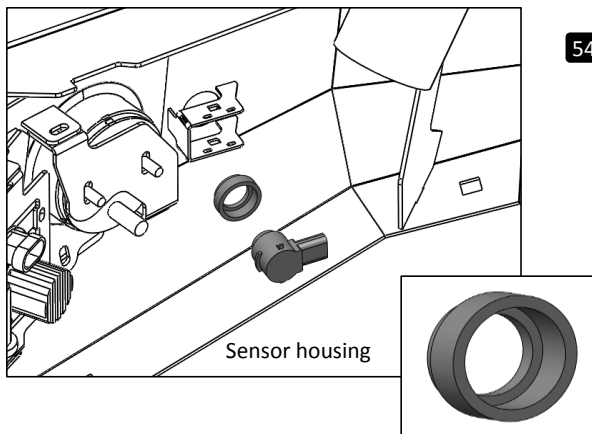
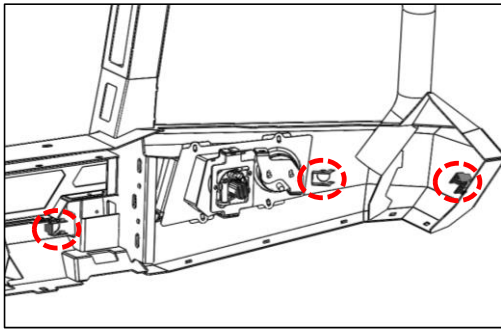

54

Insert Sensor housing on the bull bar.
Re-install the parking sensors to the bull bar.
Fit parking sensors, noting orientation,
ensuring that each one “snaps” into place.
as shown.

***Do it carefully**

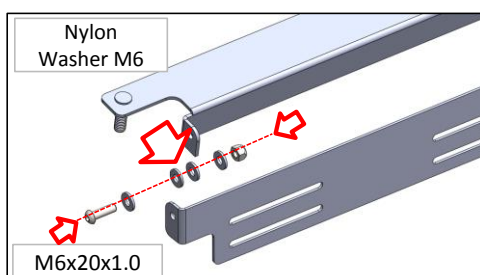
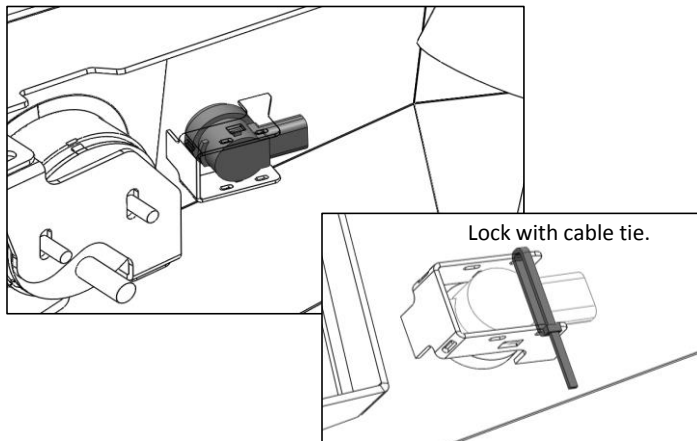

55

Assemble License plate bracket by using two M6
button head, flat washer, Nylon Washer M6 and
nyloc nut. as shown.
Do not fully tighten.

FITTING PROCEDURE

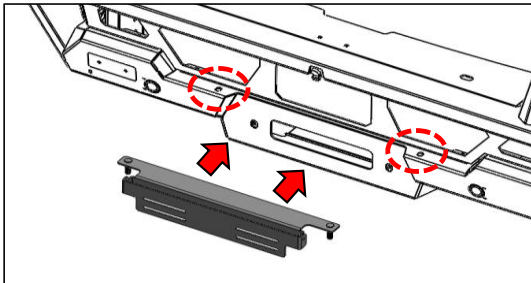

- 56** Fit License plate bracket on the bumper bar.
Using two M8 nut and flat washer. as shown.

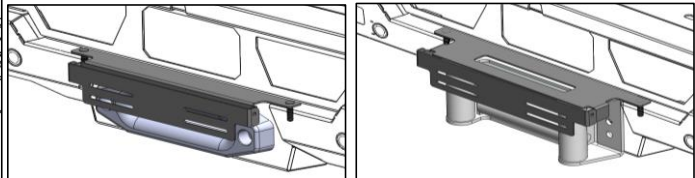

- 57** Re-install the parking sensor loom to the vehicle.

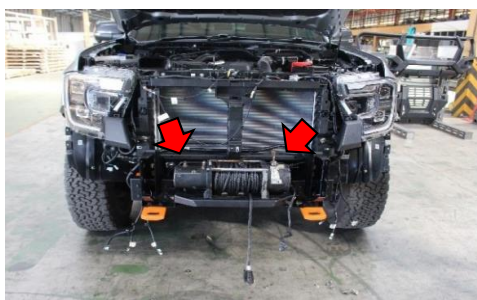

- 58** If a winch is to be fitted do so now.
Place the winch on the mounting bracket.



- 59** Lift the bumper bar onto the mounting bracket.

FITTING PROCEDURE

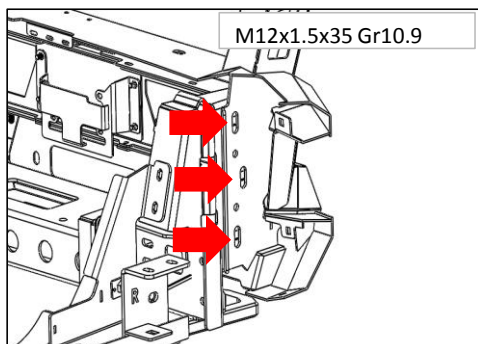

- 60 Secure bumper bar onto the mounting bracket. by using three M12 bolts(M12x1.5x35 Gr10.9), spring washers, flat washers and hex nuts.



- 61 Align the bar so there is a 20-25 mm. gap between the car and wing return of the bar and the end of the wing is in line with the wheel arch.

If the bar does not sit centrally across the front of the vehicle, loosen the chassismount and adjust accordingly.

***Repeat for the opposite side.**

***Do not tighten.**

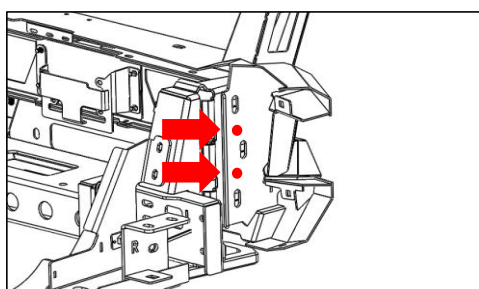

- 62 Mark the location of the holes. bumper bar to the mounting bracket.

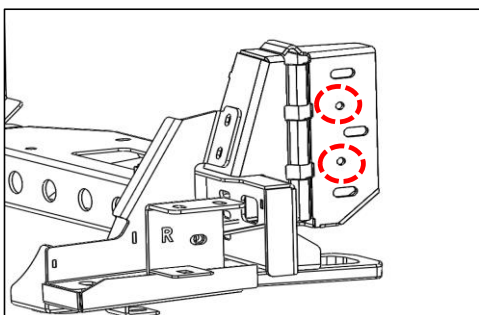

- 63 remove the bumper bar form the mounting bracket for reveal the position that has been marked. Drill two 10 mm holes through the mounting bracket and painted with rustproof paint.

FITTING PROCEDURE



M10x1.5x35 Gr10.9

M12x1.5x35 Gr10.9

- 64** Secure bumper bar onto the mounting bracket. by using three M12 bolts(M12x1.5x35 Gr10.9), spring washers, flat washers and hex nuts.using two M10 bolts(M10x1.5x35 Gr10.9), spring washers, flat washers (20 mm.) and hex nuts.

***Tighten all bolts to the correct torque.**

***Repeat for the opposite side.**



- 65** Have to extend the camera cables.

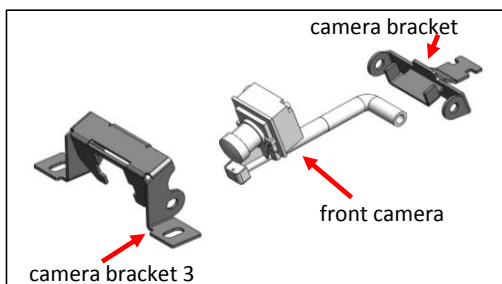

- 66** Fit the front camera to the camera bracket and camera bracket 3. as shown.

***** Do it carefully.**

FITTING PROCEDURE

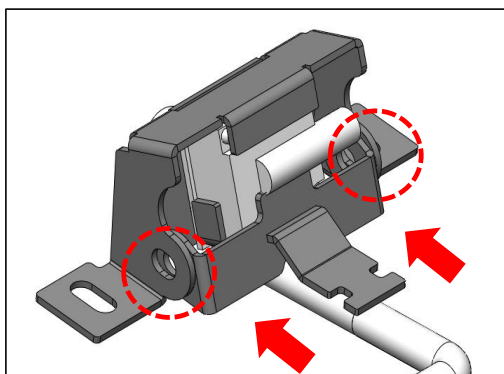

- 67** Using two Button head M5x12x0.8 ,Spring Wash,Flat Washer and Flange Nut.
***** Do it carefully.**

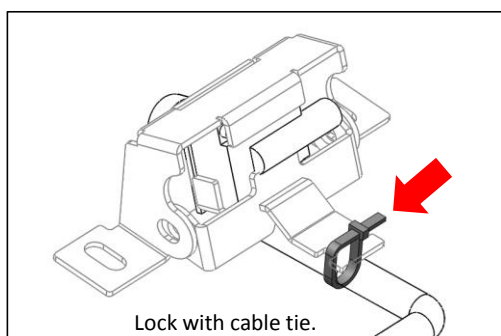

- 68** Using cable tie Lock water hose to the camera bracket .
***** Do it carefully.**

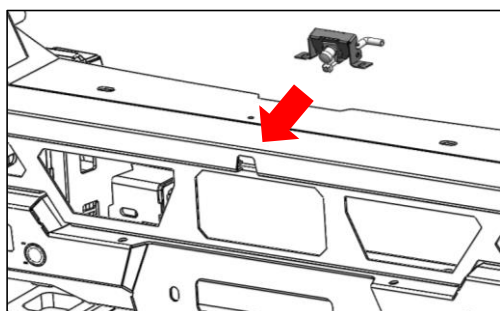

- 69** Fit the camera bracket to bumper bar.
***** Do it carefully.**

FITTING PROCEDURE

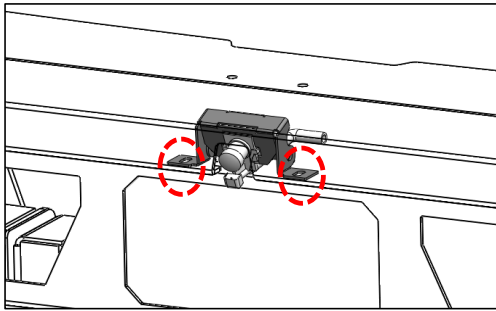

70 Using tow Button head M5x12x0.8 ,Spring Wash,Flat Washer and Flange Nut. as shown.

***** Do it carefully.**

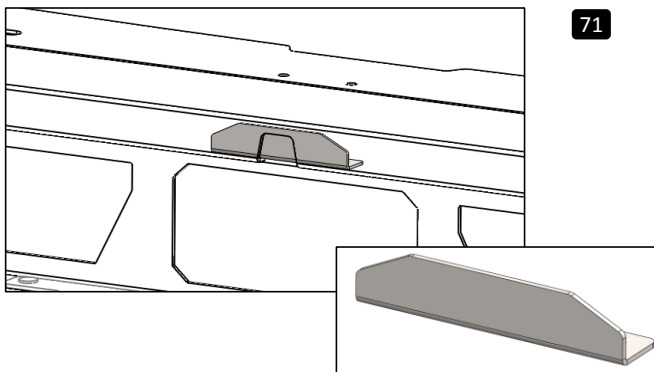

71 If you don't have a camera, use it Camera Cover to bumper bar. Using tow Button head M5x12x0.8 ,Spring Wash,Flat Washer and Flange Nut. as shown.

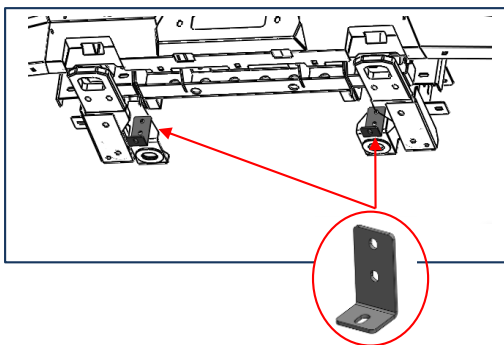

72 Secure the Protection Plate Bracket to the Support Bracket Inside. Using two M10 bolt (M8x25x1.25), spring washer , flat washer and Flange Nut.



73 Place the bottom Protection Plate center onto the vehicle.

FITTING PROCEDURE

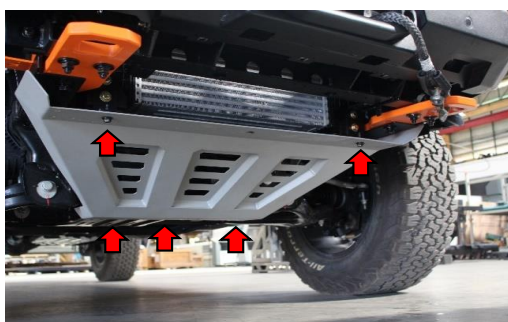

- 74** Using three M10 bolts (M10x35x1.5), spring washer and flat washer at the bottom.
Using two M10 bolts (M10x30x1.5), spring washer and flat washer at the upper.



- 75** Place the Top Protection Plate center onto the vehicle.

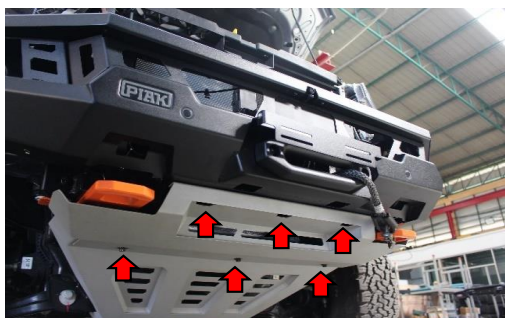

- 76** Using six M8 bolts (M8x25x1.25), spring washer and flat washer .

FITTING PROCEDURE



- 77** Secure the Wing Bracket (LH) to the bumper bar.

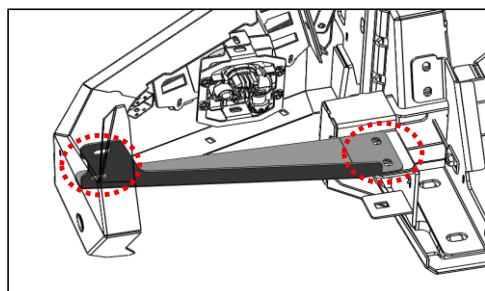

- 78** loosen the two M10 bolt .Fit the Wing Bracket on mounting bracket .

Fit the Wing Bracket on bar.
Using Two M10 bolts (M10x35x1.5), spring washer , flat washer and Hex nut .



- 79** Fold the mudguard inside to wing protection plate .



- 80** Fit the wing protection plate onto the bumper bar.

FITTING PROCEDURE

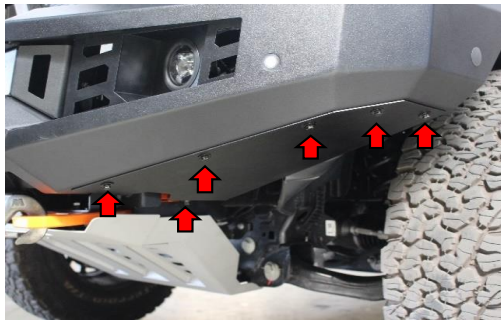

- 81** Using five (M6x20x1.0) hex bolts, spring and flat washers. Using (M8x20x1.25) hex bolts, spring, flat washers and Cage Nut .

Repeat the opposite side.



- 82** Connect wiring harness parking sensor and Fog light.



- 83** Re-fitment the front grill to the vehicle by using original bolts.



- 84** Re-fitment OEM Plastic Radiator cover attached to the top of the grille.

FITTING PROCEDURE

