



## FITTING INSTRUCTIONS



PRODUCT :

# PIAK GENESIS LOOP WINCH BAR

VEHICLE MODEL :

## ISUZU D-MAX 2024

PRODUCT PART NUMBER :

PK105ID24G\_RBO\_URPMB

PK105ID24G\_RBO\_URPBO

PK105ID24G\_RMB\_URPMB

PK105ID24G\_RMB\_URPBO

FITTING TIME :

**Approx. 3 hours**

<b>TABLE OF CONTENTS</b>	Page
Tools Required	5
Part List	5
Component Overview	9
Toque Setting of Fastener	9
Fitting Procedure	10

**BULL BAR SAFETY NOTICE :**

INSTALLATION SHOULD ONLY BE DONE BY APPROPRIATELY QUALIFIED OR EXPERIENCED PERSONS IN ACCORDANCE WITH THESE INSTRUCTIONS.

IT IS THE RESPONSIBILITY OF THE INSTALLER TO ENSURE THAT THE PRODUCT IS CORRECTLY FITTED.

**WARNING :**

Do not attach Vehicle Frontal Protection System (VFPS) to the vehicle using anchorages not intended for this purpose. (e.g. engine mounting bolts)

Do not use this product for any vehicle make or model, other than those specified by the VFPS manufacturer.

Do not remove the plaque or label from the VFPS.

Do not modify the structure of the VFPS in any way.

The VFPS has been produced to provide continued functionality of parking sensors and other "driver assist" features as closely as possible to Original Equipment. However, as all possible road conditions and combination of other accessories fitted to the vehicle which may affect functionality characteristics cannot be anticipated, **the driver remains responsible at all times for properly controlling the vehicle, monitoring all "driver assist" features and intervening where required to ensure the vehicle is safely operated.**

**IMPORTANT INFORMATION :**

Before installing the VFPS :

Check that all components, as listed in the assembly table, are available.

Thoroughly read all instructions.

This product or its fasteners must not be modified in any way.

These instructions are accurate as at the revision date and do not take into account any changes made by the vehicle manufacturer to vehicle design after the revision date or other accessories that are or have been fitted to the vehicle. Piak cannot be held responsible for such changes and appropriate enquiries should be made before installation.

Before installing, inspecting and/or maintaining the VFPS, the work space should be safe and clear of fuel, debris, electrical or other components.

During installation :

It is the responsibility of the installer to confirm correct operation/clearance of all components. All holes drilled shall have all burrs and swarf removed then coated with a suitable rust preventative paint.

Ensure that all hardware is fastened to torque list as detailed in these instructions.

## MAINTENANCE AND CARE :

To ensure continued safety and correct operation of the product, the VFPS must be routinely inspected and regularly serviced (including bolt torque checked for correct tension) by an appropriately qualified or experienced person.

The high tensile fasteners supplied with this product were used to achieve the specified rating. If replacement of the fasteners is required, fasteners of the same rating and quality must be used.

If this VFPS is fitted with a hinged number plate bracket, extra care must be taken when returning back to public roads following the use of the winch or conducting a deep water crossing.

The driver must ensure that the number plate bracket is returned back to the down position allowing full visibility of the number plate when returning to public roads.

## EQUIPMENT :

These safety products should, at a minimum, be used when fitting or working on the product.



Protective Glasses



Hearing Protection

**Installation in accordance with these instructions and adherence to warnings will ensure compliance with relevant regulatory and safety standards as at the revision date.**

**Failure to adhere to these instructions may affect the roadworthiness of the vehicle or cause personal injury, death or damage to property.**

**BY USING THIS PRODUCT YOU ACKNOWLEDGE AND AGREE THAT TO THE EXTENT PERMITTED BY LAW PIAK WILL NOT ACCEPT LEGAL OR OTHER LIABILITY FOR ANY LOSS, INJURY OR DAMAGE CAUSED BY INCORRECT OR INAPPROPRIATE INSTALLATION OR USE OF THE PRODUCT.**

**TOOLS REQUIRED**

- |                               |                            |                                      |
|-------------------------------|----------------------------|--------------------------------------|
| 1.Metric Socket and Spanners  | 2.2" Masking tape          | 3.Marking pen                        |
| 4.Drill and metric drill bits | 5.Test lamp or multi-meter | 6.Phillip and flat head screw driver |
| 7.Torque wrench               | 8.Air saw                  |                                      |

**PART LIST**

Important : Check contents of fitting kit before commencing fitment and report any discrepancies.

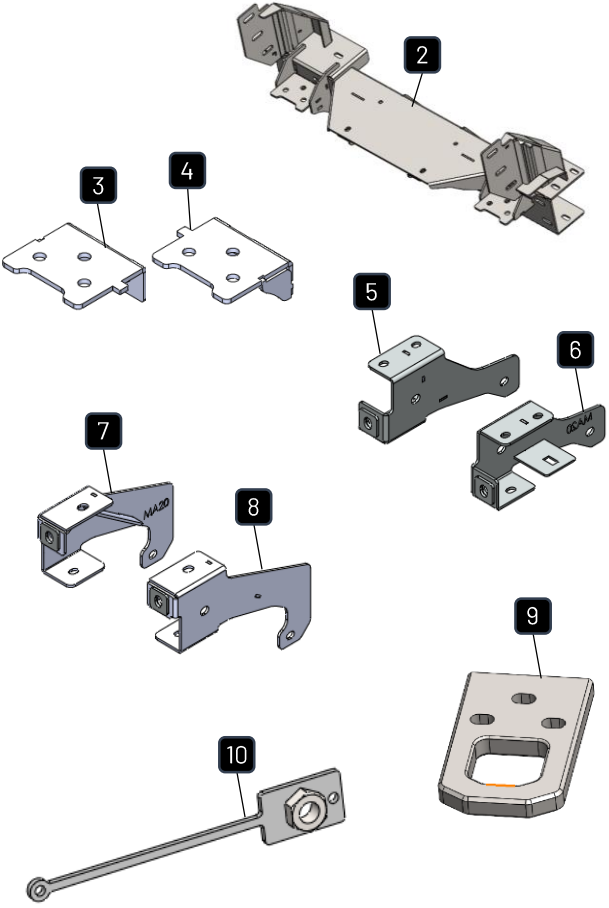
<b>STEEL BULL BAR</b>			
ITEM	COMPONENT NAME	Q'ty	REMARKS
1	PIAK Genesis Loop Bar	1	
<b>MOUNTING BRACKET</b>			
ITEM	COMPONENT NAME	Q'ty	REMARKS
2	Chassis Mounting Bracket	1	
3	Recovery Point Bracket RH	1	
4	Recovery Point Bracket LH	1	
5	Chassis Support RH	1	
6	Chassis Support LH	1	
7	Chassis Support Inside RH	1	
8	Chassis Support Inside LH	1	
9	Recovery Point	2	
10	Plate Nut M10 x 1.5P	4	
11	Hex Bolt M10x35x1.5	16	
12	Spring Washer M10	16	
13	Flat Washer M10	28	
14	Hex Nut M10x1.5	12	
15	Hex Bolt M10x35x1.5 EDP	6	
16	Spring Washer M10 EDP	10	
17	Flat Washer M10 EDP	16	
18	Hex Nut M10x1.5 EDP	6	
19	Hex Bolt M10x35x1.25 EDP	4	
20	Hex Bolt M12x55x1.5 Gr.10.9 EDP	6	
21	Spring Washer M12 EDP	6	
22	Flat Washer M12 EDP	12	
23	Hex Nut M12x1.5 Gr.10.9 EDP	6	

## PART LIST

## BAR TO MOUNTING BRACKET

ITEM	COMPONENT NAME	Q'ty	REMARKS
24	Hex Bolt M10x35x1.25	4	
25	Spring Washer M10	4	
26	Flat Washer M10 OD20	8	
27	Flange Nut M10x1.25	4	
28	Hex Bolt M12x1.5x35	6	
29	Spring Washer M12	6	
30	Flat Washer M12	12	
31	Hex Nut M12x1.5	6	

## PROTECTION PLATE (RADIATOR PIATE)

ITEM	COMPONENT NAME	Q'ty	REMARKS	
32	Top Protection Plate center	1		
33	bottom Protection Plate center AUS Version	1		
34	bottom Protection Plate center ASIA Version	1		
36	Hex Bolt M6x20x1.0	3		
37	Spring Washer M6	3		
38	Flat Washer M6	3		
39	Cage Nut M6x1.0x3T	3		
40	Hex Bolt M10x30x1.25	4		
41	Hex Bolt M10x30x1.5	5		
42	Spring Washer M10	9		
43	Flat Washer M10	12		
44	Hex Nut M10x1.5	3		
				<div style="display: flex; justify-content: space-around;"> <div style="text-align: center;"> <p><b>AUS</b></p> </div> <div style="text-align: center;"> <p><b>ASIA</b></p> </div> </div>



## PROTECTION PLATE (SIDE PLATE)

ITEM	COMPONENT NAME	Q'ty	REMARKS
45	Side Plate (LH/RH)	2	
46	Hex Bolt M6x20x1.0	12	
47	Spring Washer M6	12	
48	Flat Washer M6	12	
49	Cage Nut M6x1.0x3T	12	
50	Hex Bolt M8x30x1.25	2	
51	Spring Washer M8	2	
52	Flat Washer M8	2	
53	Cage Nut M8x1.25x3.2T	2	

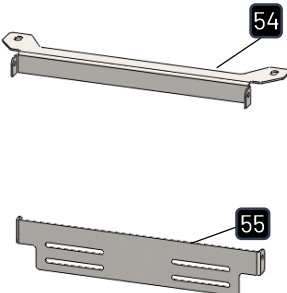
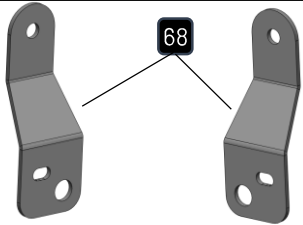
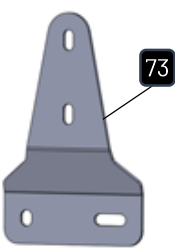
## PART LIST

LICENSE PLATE BRACKET			
ITEM	COMPONENT NAME	Q'ty	REMARKS
54	License Plate Bracket (Inner)	1	
55	License Plate Bracket (outer)	1	
56	Hex Bolt M6x20x1.0	2	
57	Spring Washer M6	2	
58	Flat Washer M6	4	
59	Flange Nut M6x1.0	2	
60	Button Head Bolt M6x20x1.0 (SUS)	2	
61	Nyloc Nut M6x1.0	2	
62	Nylon Washer M6	4	
63	Flat Washer M6 OD14 (SUS)	4	
64	Hex Bolt M8x20x1.25	2	
65	Spring Washer M8	2	
66	Flat Washer M8	4	
67	Flange Nut M8x1.25	2	
HEADLIGHT PLATE BRACKET			
ITEM	COMPONENT NAME	Q'ty	REMARKS
68	Light Support Bracket RH/LH	2	
69	Hex Bolt M6x15x1.0	2	
70	Spring Washer M6	2	
71	Flat Washer M6 OD14	4	
72	Flange Nut M6x1.0	2	
WINCH CONTROL PLATE			
ITEM	COMPONENT NAME	Q'ty	REMARKS
73	Winch Control Plate	1	
74	Hex Bolt M6x20x1.0	1	
75	Spring Washer M6	1	
76	Flat Washer M6	1	
77	Hex Bolt M8x25x1.25	1	
78	Spring Washer M8	1	
79	Flat Washer M8	2	
80	Flange Nut M8x1.25	1	

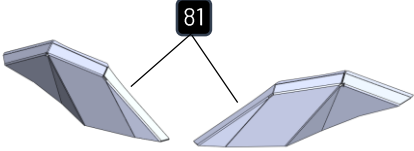
**PART LIST**

INFILL ID24G			
ITEM	COMPONENT NAME	Q'ty	REMARKS
81	Plate infilled RH/LH	2	
82	Hex Bolt M6x20x1.0	6	
83	Spring Washer M6	6	
84	Flat Washer M6	12	
85	Flange Nut M6x1.0	6	
ACCESSORIES			
ITEM	COMPONENT NAME	Q'ty	REMARKS
86	Sensor Plug 20.6 mm.	4	
87	Cable Tie (L=150 mm)	8	
88	Cable Tie Mount	3	
89	Electro Tap	6	



## COMPONENTS OVERVIEW

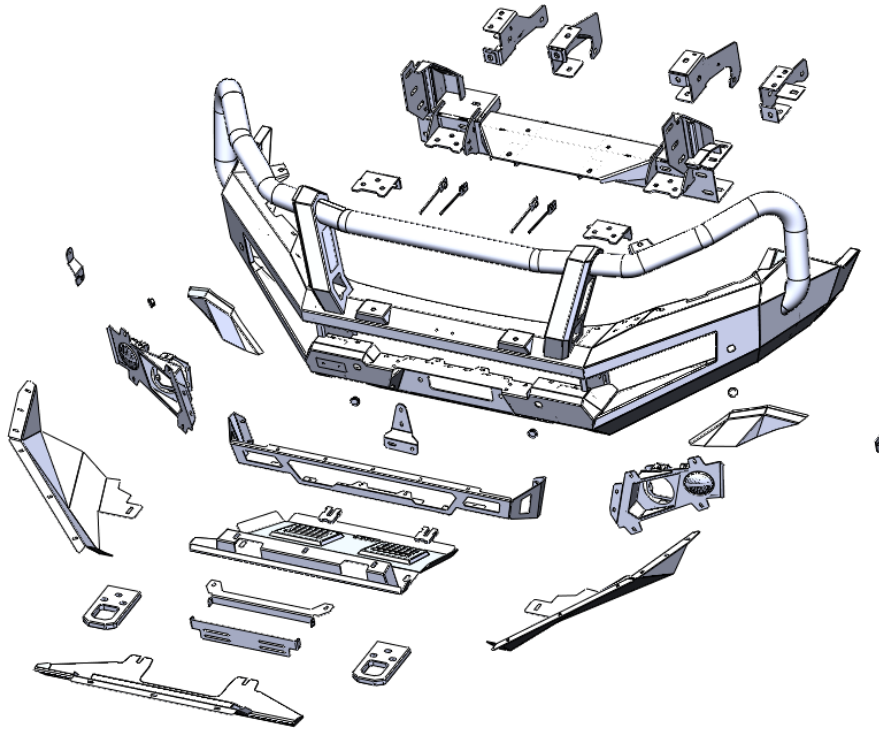

## TORQUE SETTING OF FASTENER

Mounting bolts must be tightened to torque's specified following ;

Bolt Diameter (mm.)	Class 8.8		Class 10.9	
	Torque ( Nm. )	Torque ( ft-lb. )	Torque ( Nm. )	Torque ( ft-lb. )
M6	10.5	7.7	15	11.1
M8	25.5	18.8	36.5	26.9
M10	50.5	37.2	72.2	53.3
M12	88	64.9	126	92.9
M14	140	103	200	148

**FITTING PROCEDURE**

- 1 Position the vehicle in a suitable work area.



- 2 Remove the clips and separate the air intake from the grille cover.

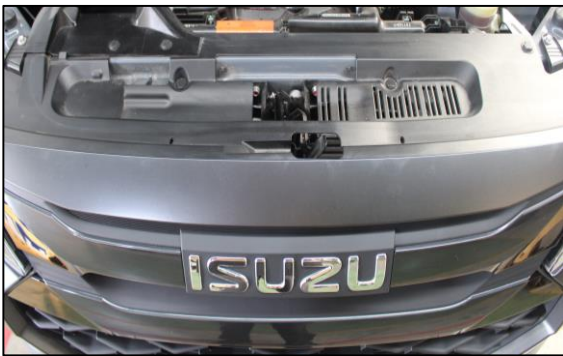

- 3 Remove the plenum cover, keeping the clips for reinstallation later.



- 4 Remove the grille cover and keep it for later use.

## FITTING PROCEDURE

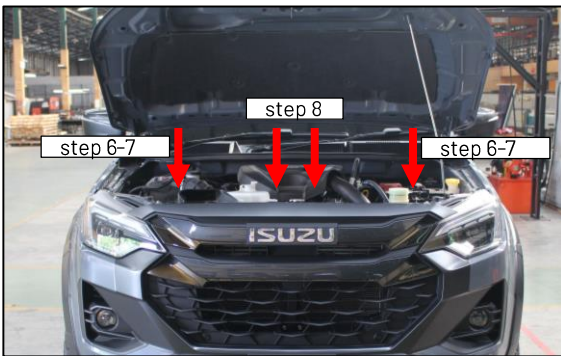

- 5 Remove the clip behind the bumper grille.  
Details and location of fasteners in steps 6-8



- 6 Remove the upper side clip behind the grille that indicates the fastener, and save it for later use  
**\*\*\* Repeat for the opposite side**



- 7 Remove the lower clip behind the grille that indicates the fastener, and save it for later use  
**\*\*\* Repeat for the opposite side**

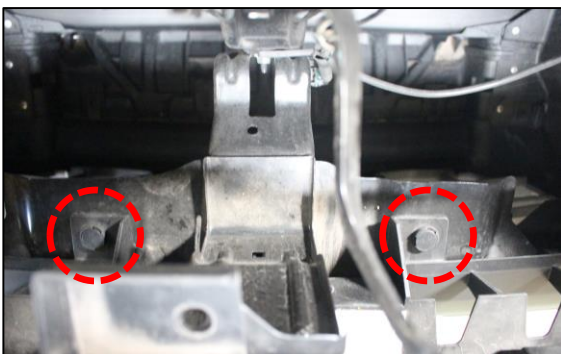

- 8 Remove the lower center clip behind the grille that indicates the fastener, and save it for later use

## FITTING PROCEDURE

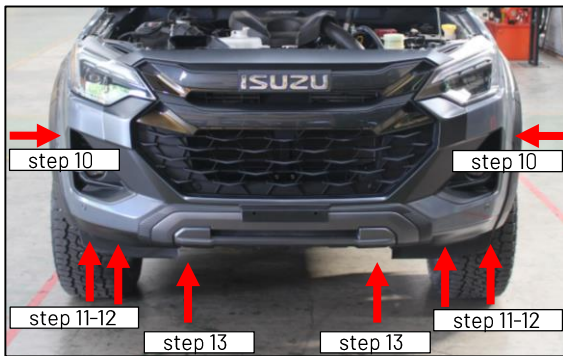

- 9** Remove the clips and screws securing the bottom of the bumper.

Details and location of fasteners in steps 10-13

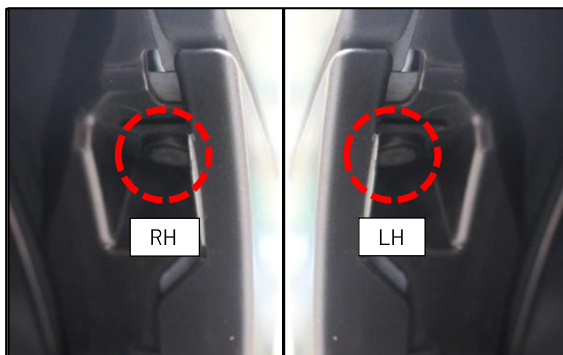

- 10** Step 10

Remove the upper clip from inside the wheel arch that secures the top of the bumper, and keep it for later use.



- 11** Step 11

Remove the indicated M6 fastener nuts from the lower bumper and discard.

**\*\*\* Repeat for the opposite side**

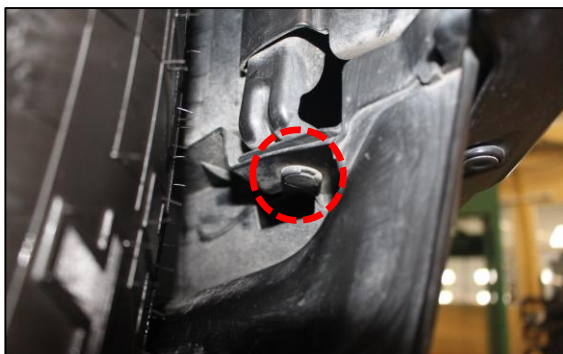

- 12** Step 12

Remove the clip that locates the lower side wheel arch from the bumper and leave them.

**\*\*\* Repeat for the opposite side**

## FITTING PROCEDURE



13

Step 13

The Skrivet must be removed at the factory tow point.

Then remove the clip inside.

**\*\*\* Repeat for the opposite side**



14

Disconnect the factory blinker wiring and fog lights from behind the bumper. If the vehicle has a front camera or parking sensors, disconnect those as well.



15

Carefully remove the bumper from the vehicle.



16

Remove the OE bumper bar retaining clip and remove and discard 1x Phillips head screw 1x M6 bolt. Do this on both sides.



## FITTING PROCEDURE

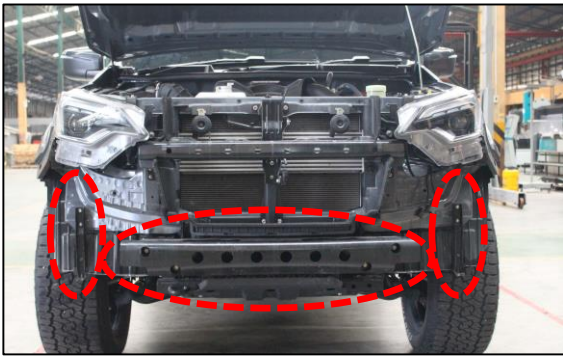

- 17 Remove and discard the center bumper support brackets and their associated fasteners.



- 18 Remove and discard the side bumper reinforcement. Repeat the steps on the opposite side.

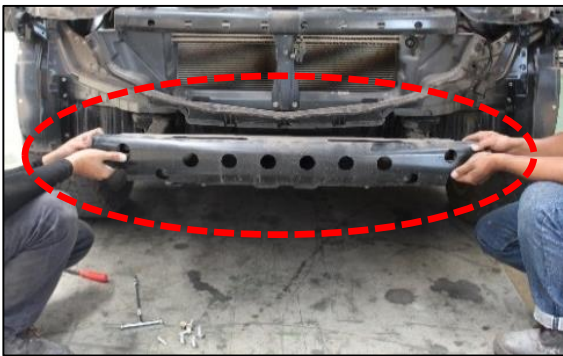

- 19 Remove and discard the center the lower impact beam.



- 20 Remove the air dam from the vehicle by unclipping its associated fasteners.

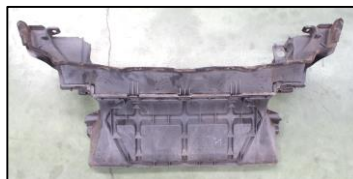

## FITTING PROCEDURE

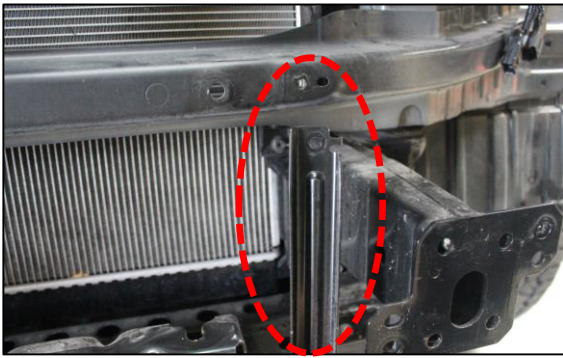

- 21 Unbolt the factory bar reinforcement.



- 22 Remove the OE small steering guard from the vehicle by taking out its associated fasteners.

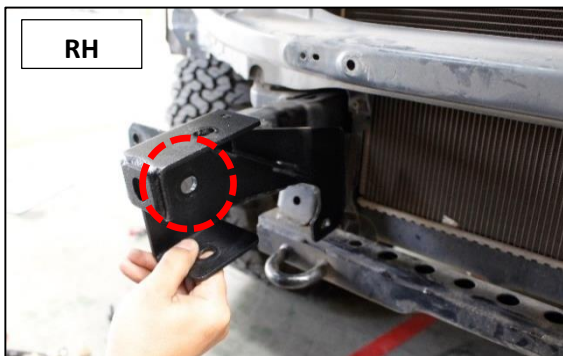

- 23 Insert the M10 x 1.5P plate nut into the hole in the chassis. Secure the chassis support inside (RH) using the hex bolt (M10x35x1.5), spring washer, flat washer, and plate nut.

\*\*\* Repeat for the opposite side.

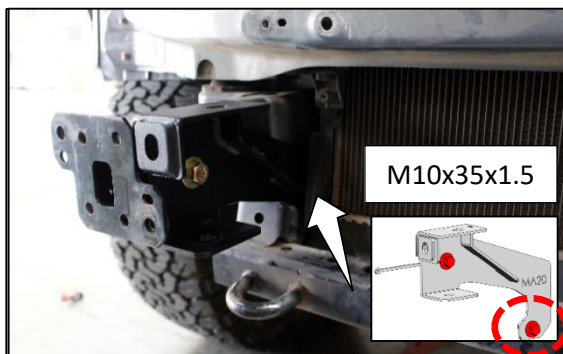
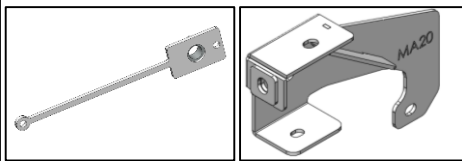

- 24 Secure the hex bolt (M10x35x1.5), spring washer, 2 x flat washer, and hex nut.

Make sure bracket is flush with chassis rail.

\*\*\* Repeat for the opposite side.

## FITTING PROCEDURE

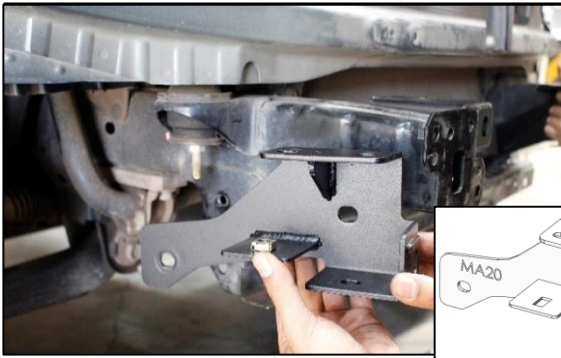

- 25** Insert the M10 x 1.5P plate nut into the chassis hole. Secure the chassis support inside (RH) with the hex bolt (M10x35x1.5), spring washer, flat washer, and plate nut.

Make sure bracket is flush with chassis rail

**\*\*\* Repeat for the opposite side.**

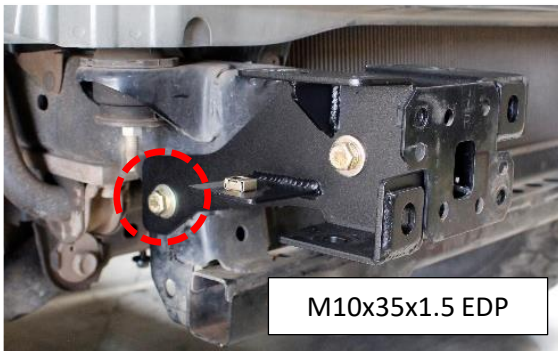

- 26** Secure the hex bolt (M10x35x1.5), spring washer, 2 x flat washer, and hex nut.

Make sure bracket is flush with chassis rail

**\*\*\* Repeat for the opposite side.**

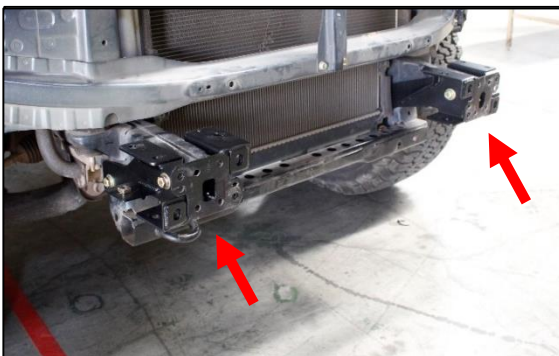

- 27** The chassis support brackets (RH and LH) are now already fitted to the vehicle.



- 28** Lift the mounting bracket onto the chassis, positioning it between the previously installed chassis supports (LH and RH).



**FITTING PROCEDURE**



**29** Secure with one hex bolt (M10x35x1.25), spring washer, and flat washer as indicated.



**30** Secure with two hex bolts (M10x35x1.5), spring washers, flat washers, and hex nuts as indicated.



**31** Secure with three hex bolts (M10x35x1.5), spring washers, flat washers, and hex nuts as indicated.

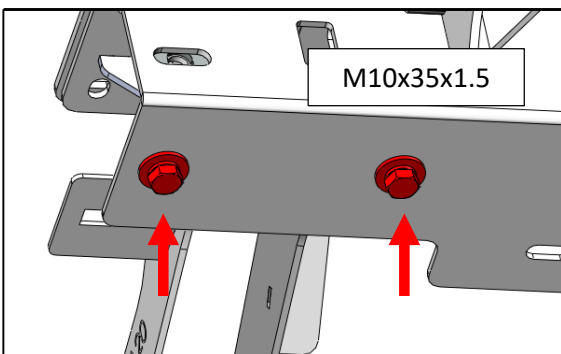

**32** Secure with two hex bolts (M10x35x1.5), spring washers, flat washers, and hex nuts as indicated.

Make sure mount is centered on vehicle not to brackets

## FITTING PROCEDURE

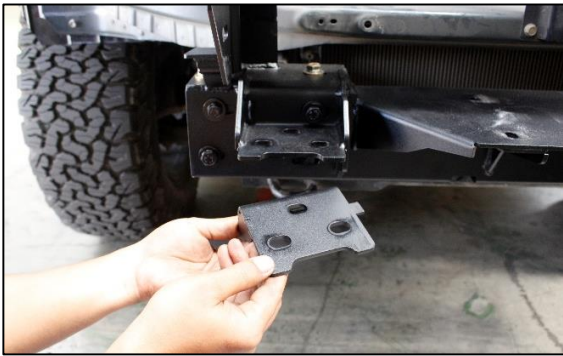

- 33 Secure the recovery point (RH) bracket at the specified location.

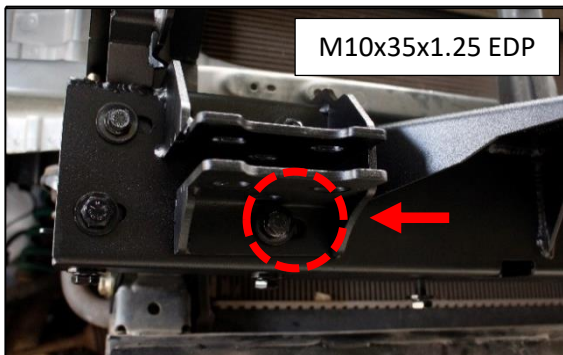

- 34 Fasten with hexagonal bolts (M10x35x1.25) spring washer and one flat washer as specified.

Install the restore point with loose fasteners.

**\*\*\* Repeat for the opposite side**



- 35 Secure the Recovery Point (RH) at location as shown.



- 36 Secure with three hex bolts Gr10.9 (M12x55x1.5), spring washers, flat washers, and hex nuts as shown.

**\*\*\* Repeat for the opposite side**

## FITTING PROCEDURE



- 37 Carefully detach the grille from the front bumper.



- 38 Measure the front grille to a distance of 50 mm from the bottom edge, as shown in the marks along the front grille.



- 39 Carefully remove the grille assembly from the front bumper.



- 40 Cut the front grille along the grille measurement line.

**FITTING PROCEDURE**



- 41** Trim the front grille along the marked cutting line using an air saw or a similar tool.



- 42** Assemble the front grille tribute parts as before.



- 43** Secure with an M6 bolt (M6x15x1.0), spring washer, flat washer, and flange nut as shown.

**\* Repeat for the opposite side.**



Secure with the OE bolt as indicated.

## FITTING PROCEDURE

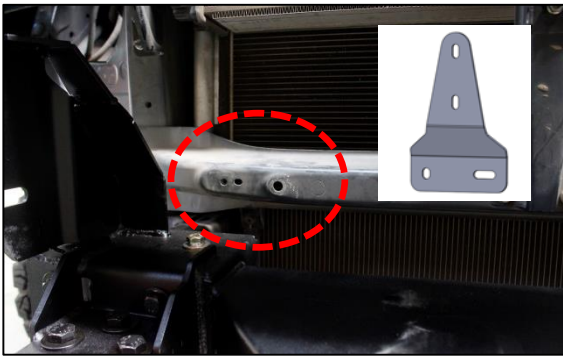

- 44 Secure the Winch Control bracket at location as shown.



- 45 Secure with hex bolts (M6x20x1.0), spring washers, and flat washers as shown. Additionally, secure with hex bolts (M8x25x1.25), spring washers, flat washers, and flange nuts as shown.

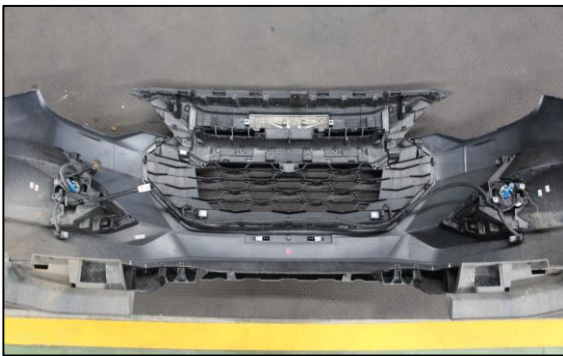

- 46 The location of the parking sensor wires (where applicable) is at the bumper bar.

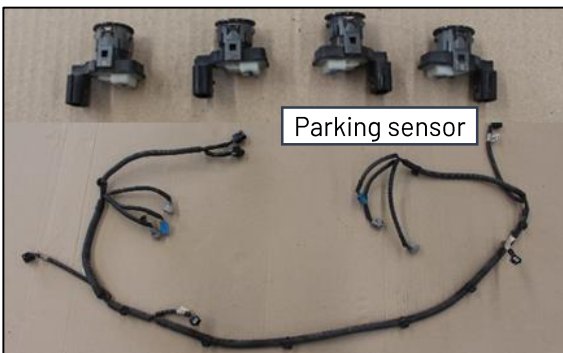

- 47 Remove the parking sensors and wiring harness from Original bumper and note the original orientation.

**\*Keep for re- fitment of bumper.**

**\*Do it carefully.**

## FITTING PROCEDURE



48 Remove the fog light from the bumper.

**\*Keep for re- fitment of bumper.**

**\*Do it carefully.**

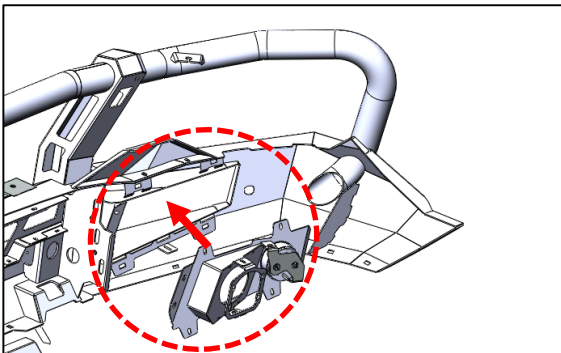

49 Attach the light frame to the bullbar .

**Using the fitting kit and Fitting instructions .**

-PKLB-LFFGOE/PKFG1-ID24G

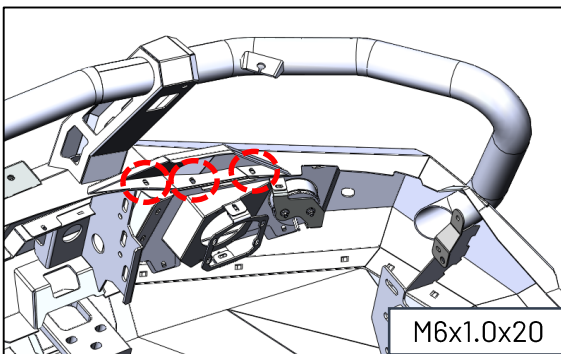

50 Fit the Plate infilled onto the bull bar using three M6 bolts (M6x1.0x20), 2x flat washers, spring washers and flange nuts as shown.

**\*Repeat for the opposite side.**

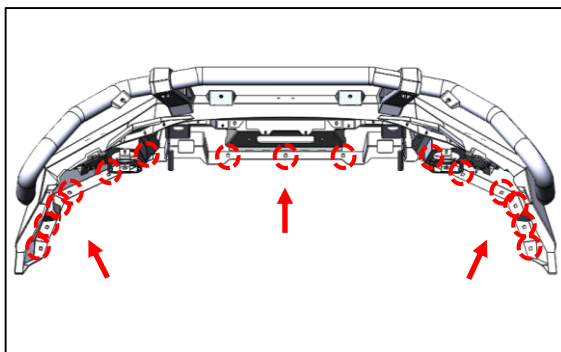
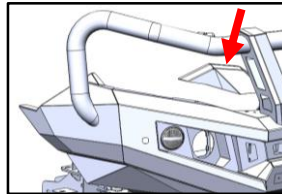

51 Insert the cage nuts (M6x1.0x3T) onto the bull bar at the indicated locations.

## FITTING PROCEDURE



- 52** To locate the parking and indicator wires, use a LED test lamp or multimeter. The wires can be found behind the headlamp inside the engine bay.

The PIAK LED harness wire codes are:

- Indicator: Yellow
- Parking: Brown
- Earth: White
- \*Repeat this process on the opposite side.

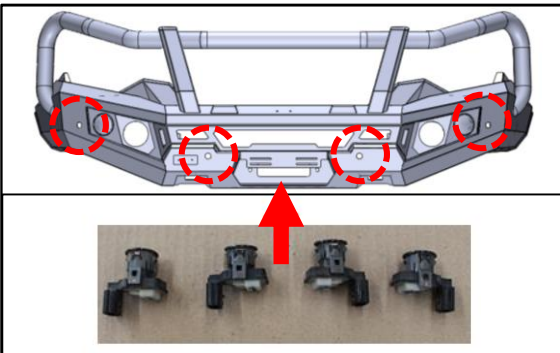

- 53** Reattach the parking sensors to the bullbar. Then, reinstall the wiring harness and connect the fog light, indicator, parking light, and parking sensors. Use electro tap to connect the indicator and parking light wires.

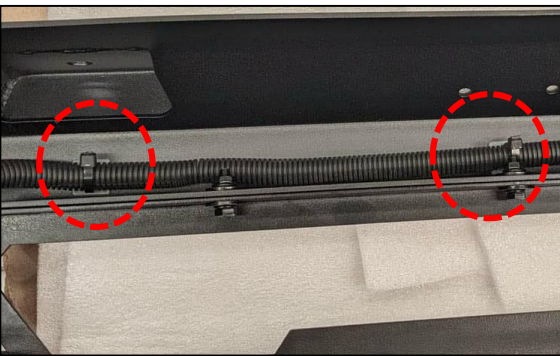
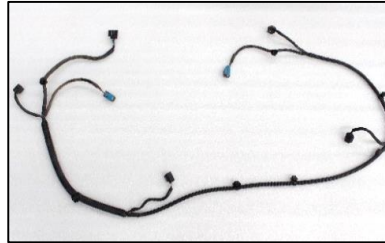

- 54** Install the Cable Tie Mount and parking sensor harness. Check each sensor to ensure proper reinstallation.



- 55** Lift the bull bar onto the vehicle

## FITTING PROCEDURE

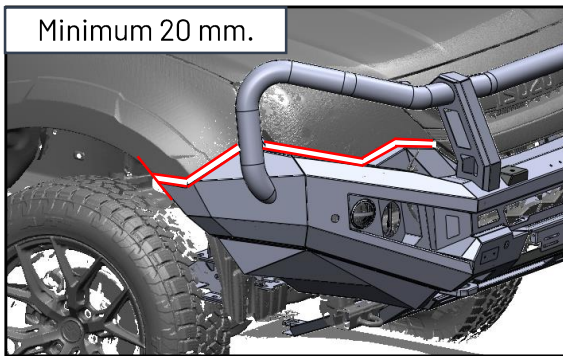

- 56** Position the bar onto the vehicle, ensuring it is centered, parallel with the wheel arch, and maintains a 20 mm gap between the quarter panel and the wing of the bar. If the bar is not centered across the front of the vehicle, loosen the chassis mount and make the necessary adjustments.

**\*\*\* Repeat for the opposite side**

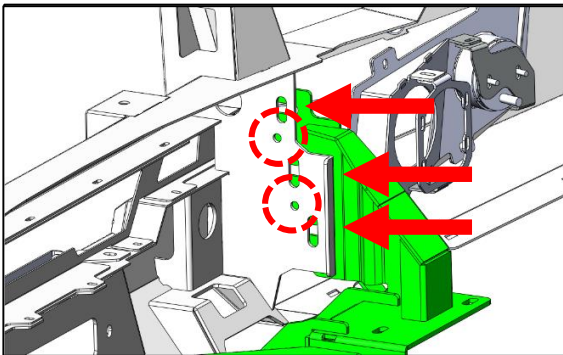

- 57** Secure the bull bar to the chassis mounting bracket using three M12 bolts (M12x1.5x35), along with spring washers, flat washers, and hex nuts.

Mark the location of the bullbar holes on the mounting bracket as shown in the picture. This is in preparation for drilling the holes in the next step

**\*Repeat for the opposite side.**

**\*Do not tighten.**

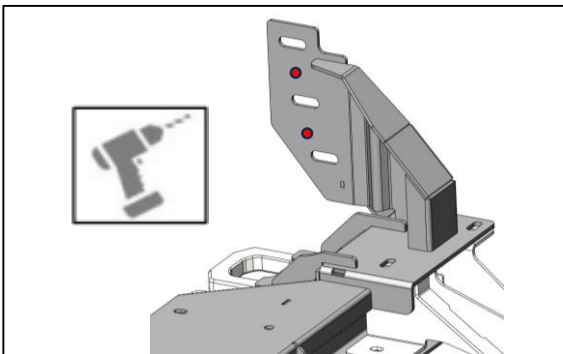

- 58** Remove the bull bar and drill two 10mm holes as marked through the chassis bracket using the holes in the steel bars as guides. Then painted with rust-proof paint.

**\*Repeat for the opposite side.**

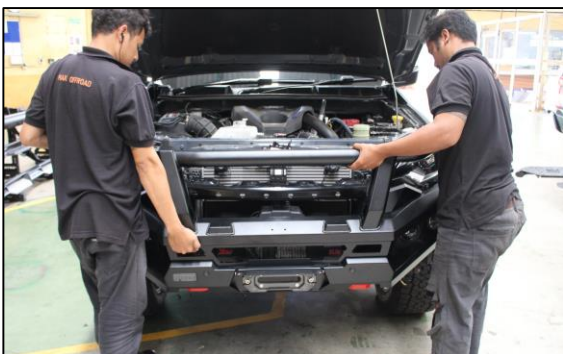

- 59** Lift the bull bar into position and align it with the chassis mounting holes

**\*\* If a bull bar assist lift isn't available, it's advised that two people handle this task to prevent injury or damage to the vehicle and its parts.**



## FITTING PROCEDURE

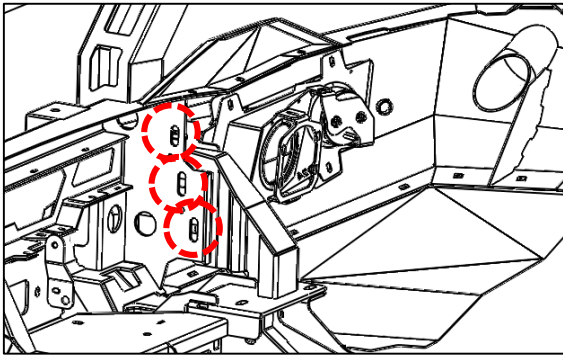

- 60** Position the bull bar into position and align it with the chassis mounting holes. Secure it in place by using three M12 bolts (M12x1.5x35), along with spring washers, flat washers, and hex nuts.

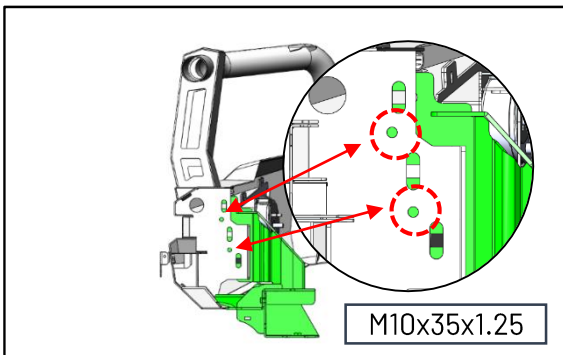

- 61** Secure with two M10 bolts (M10x35x1.25), spring washers, flat washers, and flange nuts.

**\*Tighten all bolts to the specified torque settings.**



- 62** Fit the top protection plate center onto the chassis of the vehicle as shown.



- 63** Secure with three hex bolts (M6x1.0x20), spring washers, and flat washers. Additionally, secure with two hex bolts (M10x30x1.5), spring washers, and flat washers as shown.

## FITTING PROCEDURE



- 64 Fit the bottom protection plate onto the chassis of the vehicle as shown.

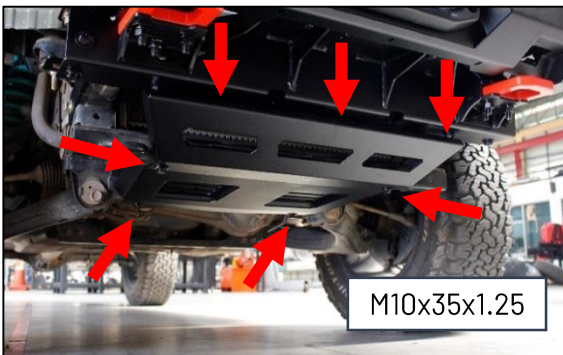

- 65 Secure with three hex bolts (M10x30x1.5), spring washers, flat washers, and hex nuts. Additionally, secure with four hex bolts (M10x30x1.25), spring washers, and flat washers as shown.

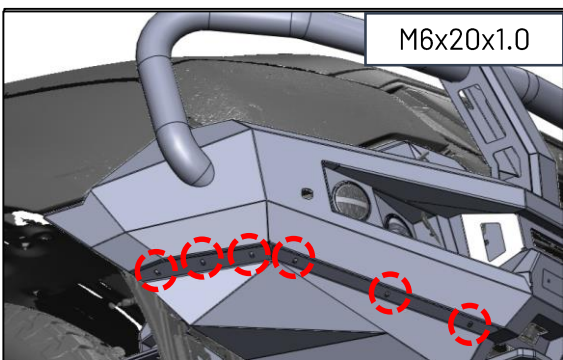

- 66 Secure with five hex bolts (M6x1.0x20), spring washers, and flat washers as shown.

**\*\*\* Repeat for the opposite side.**

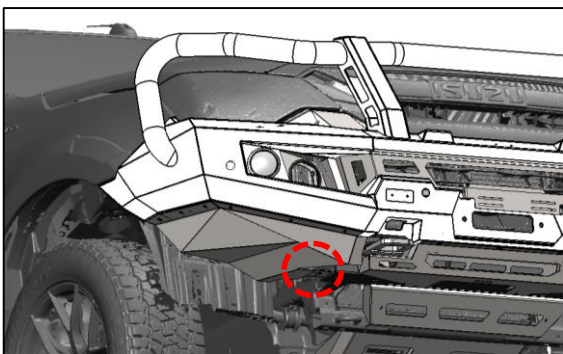

- 67 Additionally, secure with hex bolts (M8x1.25x20), spring washers, and flat washers as indicated as shown.

**\*Repeat for the opposite side.**

## FITTING PROCEDURE

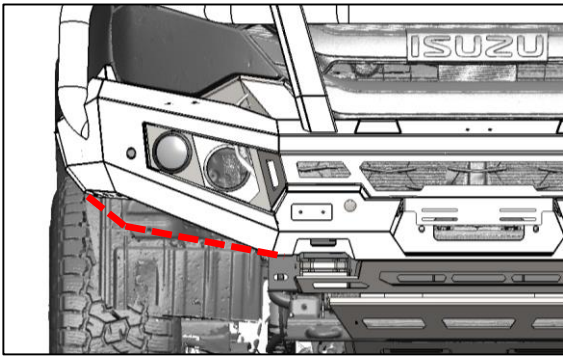

- 68** Hold the wing protection plate in position and mark the guard liner for trimming. Trim the guard liner accordingly .

**\*Repeat for the opposite side.**



- 69** Drill holes to attach the mudguard. Then tighten using the OEM Bolt.



- 70** Reinstall the clips to the OEM plastic radiator cover and grille cover.

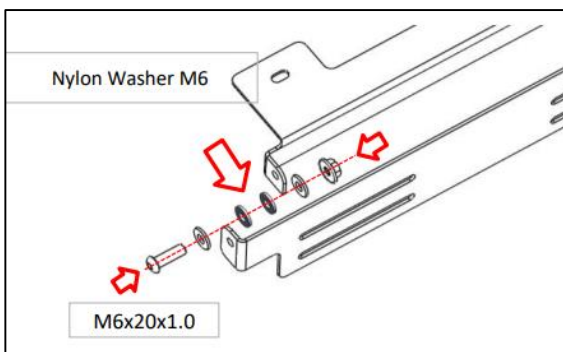

- 71** Assemble the license plate bracket using two M6 button head bolts, flat washers, nylon washers, and nyloc nuts as shown.

## FITTING PROCEDURE

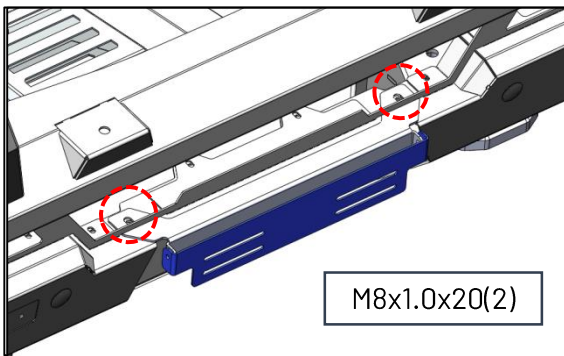

- 72 Fit the assembled license plate bracket to the bull bar using M8 bolts (M8x20x1.0), spring washers, flat washers, and flange nuts.



The PIAK Genesis Bar for Isuzu D-Max MY24 is now fully installed.