



PERMIUM REAR STEP TOW BAR WITH SIDE PROTECTION

FITTING INSTRUCTIONS



MITSUBISHI TRITON DOUBLE CAB 2019 ON

PK204MT19DC

Fitting Time : approx. 1 hours

TOW BAR SAFETY NOTICE:

INSTALLATION SHOULD ONLY BE DONE BY APPROPRIATELY QUALIFIED OR EXPERIENCED PERSONS IN ACCORDANCE WITH THESE INSTRUCTIONS.

IT IS THE RESPONSIBILITY OF THE INSTALLER TO ENSURE THAT THE PRODUCT IS CORRECTLY FITTED.

WARNING:

Do not attach the tow bar to the vehicle using fasteners other than provided.

Do not use this product for any vehicle make or model, other than those specified.

Do not remove the plaque or label from the tow bar.

Do not modify the structure of the tow bar in any way.

This product has been produced to provide continued functionality of parking sensors and other "driver assist" features as closely as possible to Original Equipment. However, as all possible road conditions and combination of other accessories fitted to the vehicle which may affect functionality characteristics cannot be anticipated, the driver remains responsible at all times for properly **controlling the vehicle, monitoring all "driver assist" features and intervening where required to** ensure the vehicle is safely operated.

This product is for towing purposes only. Exceeding the specified towing capacity of the vehicle is dangerous and can void vehicle warranties. Please always refer to the vehicle owner's manual or the manufacturer for towing capacity specifications.

IMPORTANT INFORMATION:

Before installing the product:

Check that all components, as listed in the assembly table, are available.

Thoroughly read all instructions.

This product or its fasteners must not be modified in any way.

These instructions are accurate as at the revision date and do not take into account any changes made by the vehicle manufacturer to vehicle design after the revision date or other accessories that are or have been fitted to the vehicle. PIAK cannot be held responsible for such changes and appropriate enquiries should be made before installation.

Before installing, inspecting and/or maintaining the product, the work space should be safe and clear of fuel, debris, electrical or other components.

During installation:

It is the responsibility of the installer to confirm correct operation/clearance of all components.

All holes drilled shall have all burrs and swarf removed then coated with a suitable rust preventative paint.

Ensure that all hardware is fastened to torque list as detailed in these instructions.

MAINTENANCE AND CARE:

To ensure continued safety and correct operation of the product, the product must be routinely inspected and regularly serviced (including bolt torque checked for correct tension) by an appropriately **qualified or experienced person**. **Pull Pins and "R" clips must be regularly checked for proper installation**. Replace any worn or defective parts.

Tow ball mounts, tongues or lugs should be removed when not actually towing so as to produce an unobscured view of the vehicles registration plate, and to also provide maximum available departure angle.

It is recommended that the tongue, Pull Pin and R-clip are removed when not towing and stored in a safe, clean and dry place.

PIAK recommends that you check your tow ball to ensure that it complies with the Australian Standard AS 4177.2.

EQUIPMENT:

These safety products should, at a minimum, be used when fitting or working on the product.



Protective Glasses



Hearing Protection

Installation in accordance with these instructions and adherence to warnings will ensure compliance with relevant regulatory and safety standards as at the revision date.

Failure to adhere to these instructions may affect the roadworthiness of the vehicle or cause personal injury, death or damage to property.

BY USING THIS PRODUCT YOU ACKNOWLEDGE AND AGREE THAT TO THE EXTENT PERMITTED BY LAW PIAK WILL NOT ACCEPT LEGAL OR OTHER LIABILITY FOR ANY LOSS, INJURY OR DAMAGE CAUSED BY

TOOLS REQUIRED

1. Metric socket and spanners
2. Phillips and flat head screw driver
3. Torque wrench
4. Soldering iron and electrical tape

PARTS LIST

⚠ Important : Check contents of fitting kit before commencing fitment and report any discrepancies.

Steel Rear Bar			
Item	Component Name	Q'ty	Remarks
1	Rear Bar	1	
2	Plate Bolt 1 (M12x1.5)	2	
3	Plate Bolt 2 (M12x1.5)	2	
4	D Shackle rated WLL 1T	2	
5	Hex Bolt M12x35x1.5	4	
6	Spring Washer M12	10	
7	Flat Washer M12	10	
8	Plate nut M12X1.5	4	
9	Hex Nut M12x1.5	6	
Sonar Bracket			
Item	Component Name	Q'ty	Remarks
10	Sonar Bracket (LH&RH)	2	
11	Button Head Bolt M8x1.25x30	4	
12	Flat Washer M8	8	
13	Spring Washer M8	4	
14	Flange Nut M8x1.25	4	
15	Hex Bolt M6x1.0x30	4	
16	Flat Washer M6	8	
17	Spring Washer M6	4	
18	Flange Nut M6x1.0	4	
Sensor Plug			
Item	Component Name	Q'ty	Remarks
19	Sensor housing D18.5x10	4	
20	Sensor blanking Plugs	4	

COMPONENTS OVERVIEW

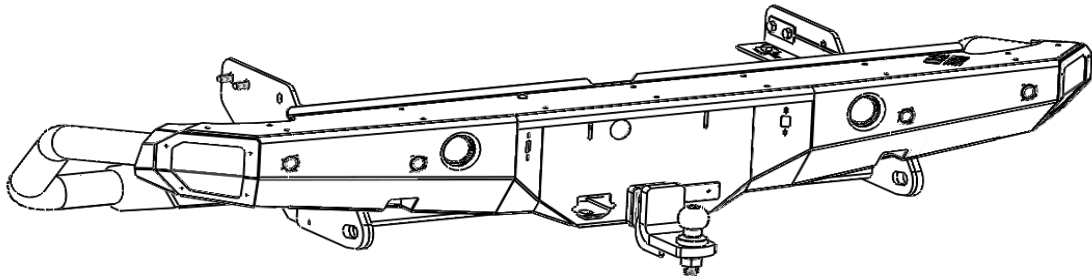

TORQUE SETTING OF FASTENER

Mounting bolts must be tightened to torque's specified following ;

Bolt Diameter (mm.)	Torque (Nm)	Torque (ft.lb)
M6	9	7
M8	22	16
M10	44	32
M12	77	57

FITTING PROCEDURE



- 1 Locate the vehicle in a suitable position.



- 2 Remove the original bumper from vehicle and place on a soft surface.

Notice : Refer to vehicle repair manual for correct removal manual.



- 3 Unclip the wiring looms coming from behind the bumper bar.



- 4 Carefully remove the bumper from the vehicle. If unsure about bumper removal refer to the workshop manual

FITTING PROCEDURE



5 original bumper .



6 Remove the plastic back cover.

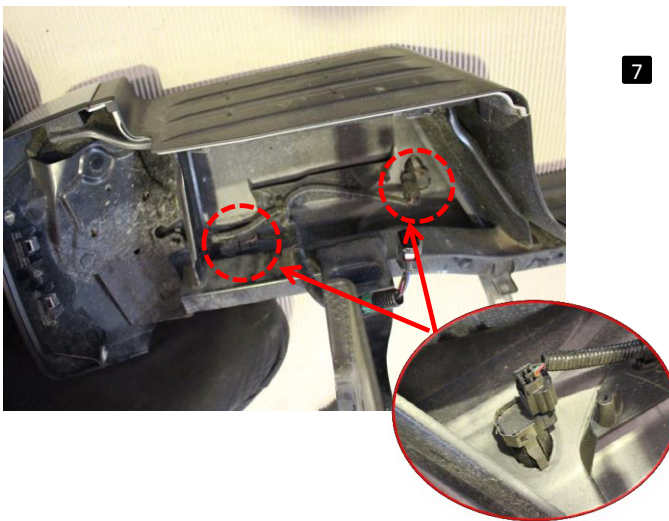

7 Carefully remove parking sensors mount bracket from bumper making sure not damage the bracket in the process.

*****Note the location of each parking sensor. *****



8 Remove the top plastic cover and remove the M6 hex bolt.

FITTING PROCEDURE



- 9 Remove the plastic center cover. remove the tow M6 hex bolt.



- 10 Remove the three M6 hex nut.



- 11 Remove the Sonar sensor and parking sensor loom from the bumper bar.

Repeat for the opposite side.

FITTING PROCEDURE

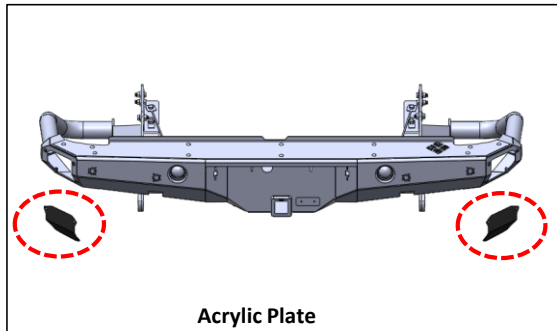

- 12** Fit the Acrylic Plate on the rear bar inside.

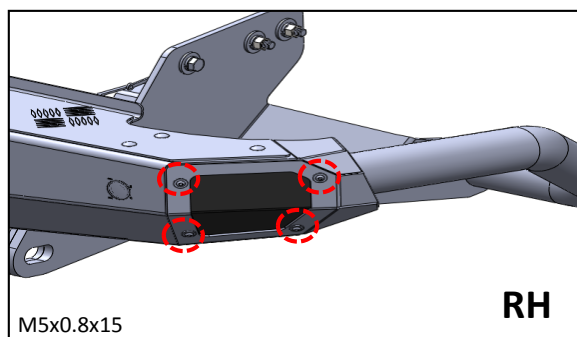
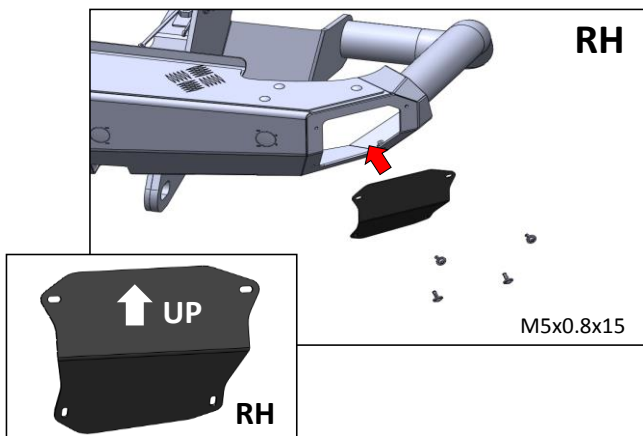

- 13** Using four Button Head Bolt M5x0.8x15 , spring ,flat washers and flange nut. as shown.

Repeat for the opposite side.

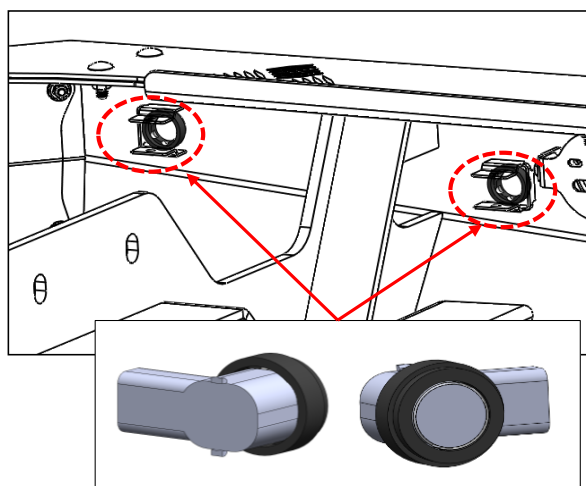

- 14** Insert Sensor housing on the rear bar.

Repeat for the opposite side.

FITTING PROCEDURE

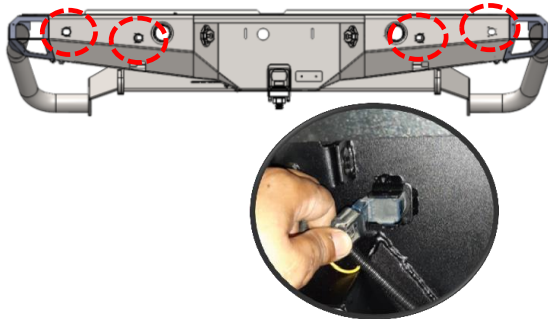

- 15** Re - install the parking sensor surrounds and parking sensors to the rear bar .

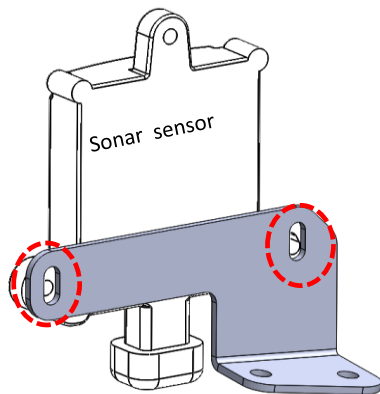

- 16** Secure the Sonar sensor to the Sonar Bracket assembly with two M6 x 1.0 x 20mm hex bolts, M6 spring ,flat washers and flange nut.as shown.

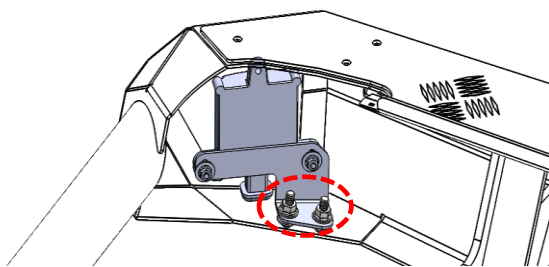

- 17** Fit the Sonar sensor Bracket assembly onto the rear bar.Using two Button Head Bolt M8x1.25x30 , M6 spring ,flat washers and flange nut. as shown.

Repeat for the opposite side.

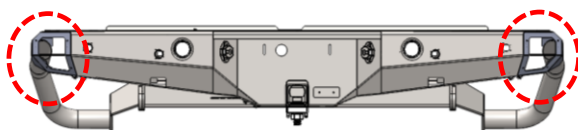

- 18** Sonar sensor position.

FITTING PROCEDURE



- 19** Insert Plate Bolt 1 (M12x1.5) into the LH /RH chassis bottom mount of vehicle as shown.



- 20** Lift the rear bar onto the chassis of vehicle. Secure with tow M12 nut, spring washers and flat washers

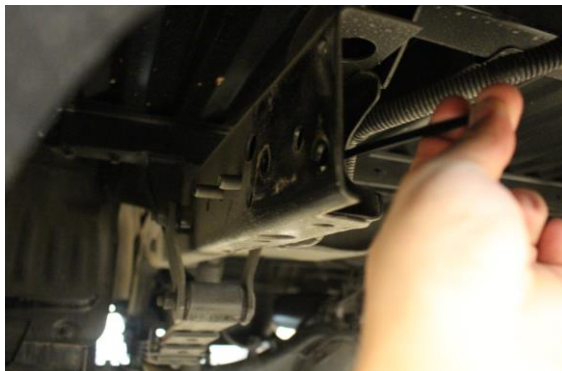

- 21** Insert Plate Bolt 2 (M12x1.5) into the LH /RH chassis bottom mount of vehicle as shown. Secure with t four M12 nut, spring washers and flat washers.

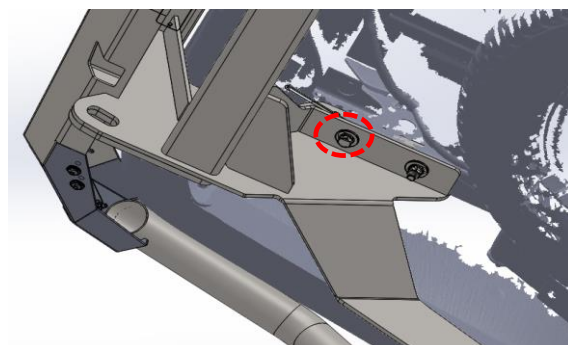

- 22** Secure with one M12 bolts (M12x35x1.5), spring washers, flat washers and plate nuts at the bottom of mounting bar as shown.

Repeat for the opposite side.

FITTING PROCEDURE

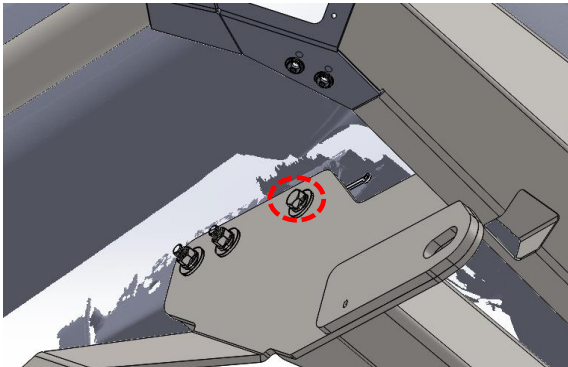

- 23** Secure with one M12 bolts (M12x35x1.5), spring washers, flat washers and plate nuts at the side of mounting bar as shown.

Repeat for the opposite side.

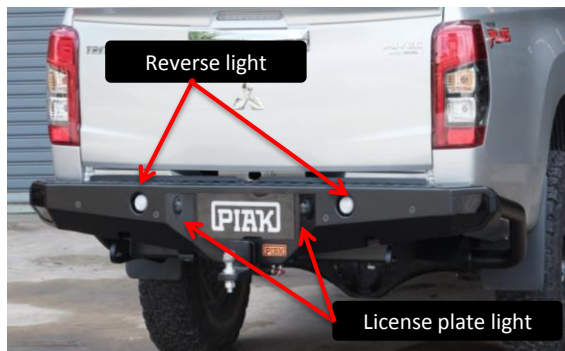

- 24** Connect Reverse light and License plate light original to bar.

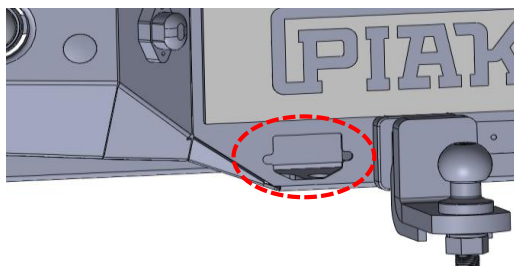

- 25** Location for installing trailer plug the position as shown .

FITTING PROCEDURE

