



# UNDERBODY PROTECTION RADIATOR PLATE/ENGINE PLATE

## FITTING INSTRUCTIONS



## TOYOTA HILUX VIGO 2011-2014

PK105/106TH11-URP-UEP-MB  
PK105/106TH11-URP-UEP-B0

**Fitting Time : approx. 30 minute.**

#### UNDER BODY SAFETY NOTICE:

INSTALLATION SHOULD ONLY BE DONE BY APPROPRIATELY QUALIFIED OR EXPERIENCED PERSONS IN ACCORDANCE WITH THESE INSTRUCTIONS.

IT IS THE RESPONSIBILITY OF THE INSTALLER TO ENSURE THAT THE PRODUCT IS CORRECTLY FITTED.

#### WARNING:

Do not attach the underbody to the vehicle using fasteners other than provided.

Do not use this product for any vehicle make or model, other than those specified.

Do not remove the plaque or label from the underbody

Do not modify the structure of the **underbody** in any way.

#### IMPORTANT INFORMATION:

Before installing the PIAK Products:

- Check that all components, as listed in the assembly table, are available.
- Thoroughly read all instructions.

This product or its fasteners must not be modified in any way.

These instructions are accurate as at the revision date and do not take into account any changes made by the vehicle manufacturer to vehicle design after the revision date or other accessories that are or have been fitted to the vehicle. PIAK cannot be held responsible for such changes and appropriate enquiries should be made before installation.

Before installing, inspecting and/or maintaining the PIAK Products, the work space should be safe and clear of fuel, debris, electrical or other components.

During installation:

- It is the responsibility of the installer to confirm correct operation/clearance of all components.
- All holes drilled shall have all burrs and swarf removed then coated with a suitable rust preventative paint.
- Ensure that all hardware is fastened to torque list as detailed in these instructions.

#### MAINTENANCE AND CARE:

To ensure continued safety and correct operation of the PIAK Products. It must be routinely inspected and regularly serviced (including bolt torque checked for correct tension) by an appropriately qualified or experienced person.

The high tensile fasteners supplied with this product were used to achieve the specified rating. If replacement of the fasteners is required, fasteners of the same rating and quality must be used.

EQUIPMENT:

These safety products should, at a minimum, be used when fitting or working on the product.



Protective Glasses



Hearing Protection

Installation in accordance with these instructions and adherence to warnings will ensure compliance with relevant regulatory and safety standards as at the revision date.

BY USING THIS PRODUCT YOU ACKNOWLEDGE AND AGREE THAT TO THE EXTENT PERMITTED BY LAW PIAK WILL NOT ACCEPT LEGAL OR OTHER LIABILITY FOR ANY LOSS, INJURY OR DAMAGE CAUSED BY INCORRECT OR INAPPROPRIATE INSTALLATION OR USE OF THE PRODUCT.

## TOOLS REQUIRED

1. Metric socket and spanners
2. Phillips and flat head screw driver

## PARTS LIST

**⚠ Important :** Check contents of fitting kit before commencing fitment and report any discrepancies.

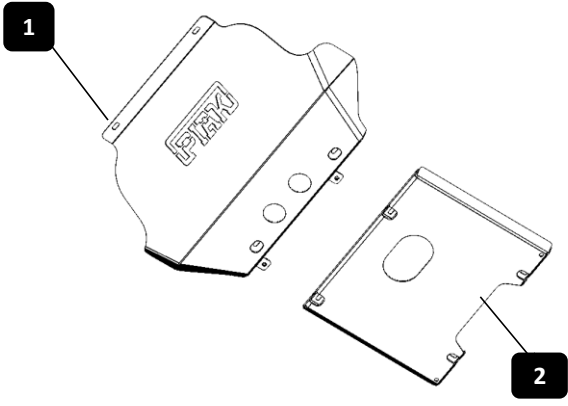
Underbody Protection Plate			
Item	Component Name	Q'ty	Remarks
1	Radiator Plate	1	
2	Engine Plate	1	
3	Hex Bolt M8x1.25x30	6	
4	Flat Washer M8	6	
5	Spring Washer M8	6	
6	Hex Bolt M10x1.25x35	2	
7	Flat Washer M10	4	
8	Spring Washer M10	2	
9	Flange Nut M10x1.25	2	

## COMPONENTS OVERVIEW

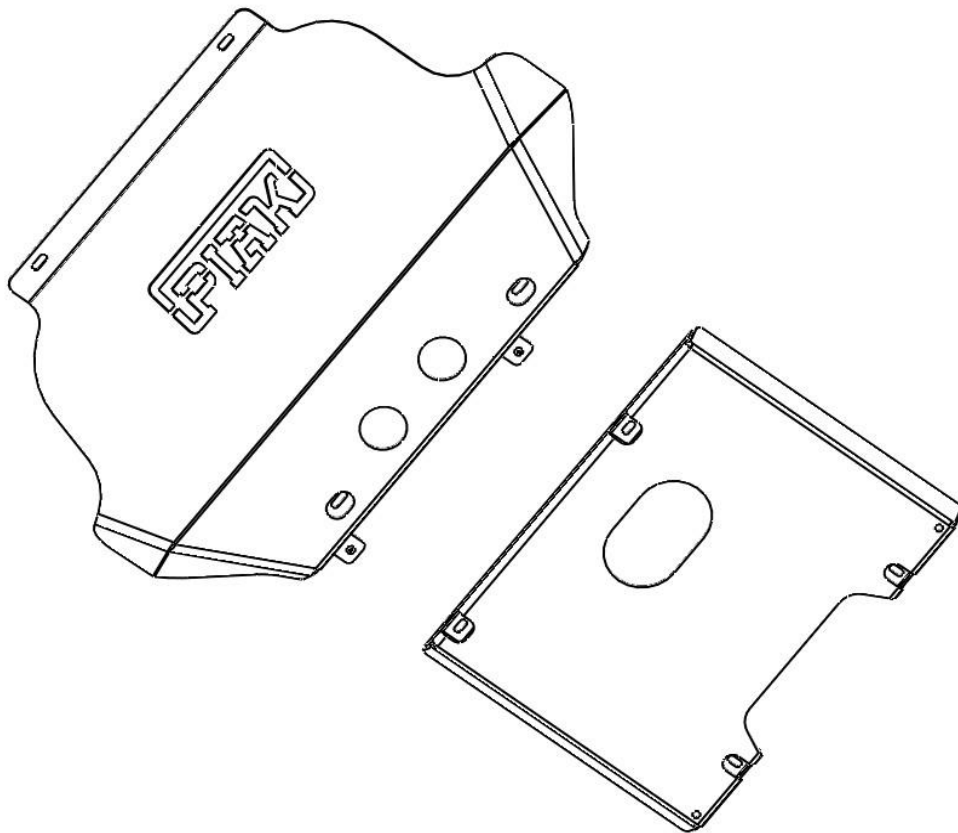

## TORQUE SETTING OF FASTENER

Mounting bolts must be tightened to torque's specified following ;

Bolt Diameter (mm.)	Class 8.8		Class 10.9	
	Torque ( Nm. )	Torque ( ft-lb. )	Torque ( Nm. )	Torque ( ft-lb. )
<b>M6</b>	10.5	7.7	15	11.1
<b>M8</b>	25.5	18.8	36.5	26.9
<b>M10</b>	50.5	37.2	72.2	53.3
<b>M12</b>	88	64.9	126	92.9
<b>M14</b>	140	103	200	148

## FITTING PROCEDURE

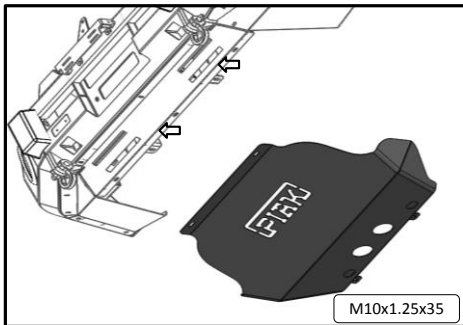

- 1 Locate the vehicle in a suitable area.
- 2 Fit Radiator Plate onto the Mount bracket by securing two M10 bolts (M10x1.25x35), spring washers, flat washers and Flange nut.

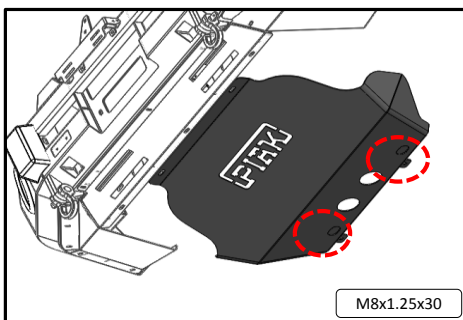

- 3 Fit Radiator Plate onto the Original location by securing two M8 bolts (M8x30x1.25), spring washers and flat washers.

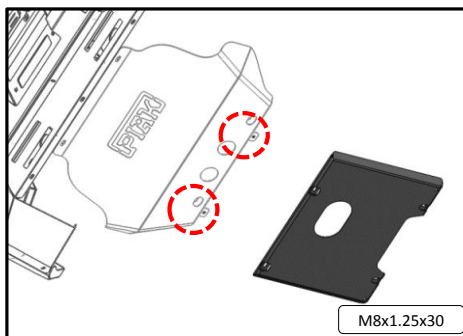

- 4 Fit Engine Plate onto the Radiator Plate by securing M8 bolts (M8x30x1.25), spring washers and flat washers.

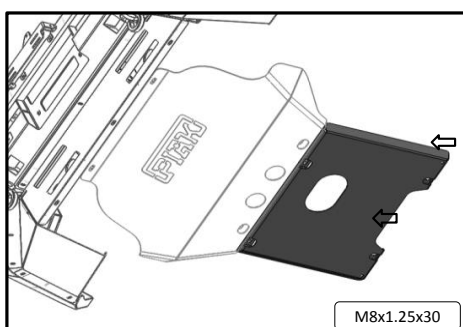

- 5 Fit Engine Plate onto the Original location by securing two M8 bolts (M8x30x1.25), spring washers and flat washers.

## FITTING PROCEDURE

