

THE POWER OF

REDARC®

SOLAR

Solar Regulator

SRP0120 / SRP0240

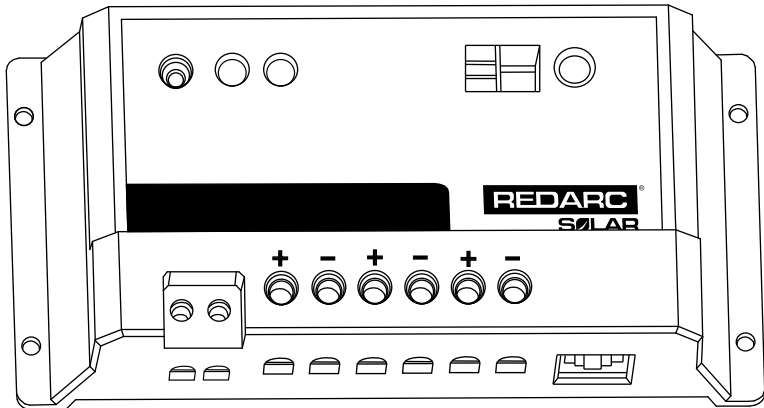

THE SOLAR REGULATOR

REDARC solar regulators ensure that the power supplied by your solar panels is at the right voltage to charge your auxiliary batteries. REDARC solar regulators are PWM controlled and incorporate automatic system voltage detection. Our solar regulators are suitable for charging up to two separate battery banks and come in both 10 A and 20 A models which are capable of charging either 12 V or 24 V battery systems.

WARNING & SAFETY INSTRUCTIONS

SAVE THESE INSTRUCTIONS — THIS MANUAL CONTAINS IMPORTANT SAFETY INSTRUCTIONS FOR REDARC SOLAR REGULATORS.

DO NOT OPERATE THE SOLAR REGULATOR UNLESS YOU HAVE READ AND UNDERSTOOD THIS MANUAL AND THE SYSTEM IS SETUP AS PER THESE INSTRUCTIONS. REDARC RECOMMENDS THAT ANY REGULATOR/CHARGER BE INSTALLED BY A SUITABLY QUALIFIED PERSON.

WARNING

RISK OF EXPLOSIVE GASES:

Working in the vicinity of a Lead-Acid battery is dangerous. Batteries generate explosive gases during normal operation. For this reason, it is of utmost importance that you follow the instructions each time you use the Regulator.

CAUTION

1. Solar Regulators should not be used by persons (including children) with reduced physical, sensory or mental capabilities, or lack of experience and knowledge, unless they are supervised or have been instructed on how to use the appliance by a person responsible for their safety. Children should be supervised to ensure that they do not play with the Solar Regulator.
2. Do NOT use the Solar Regulator to charge non-rechargeable batteries. Doing so may result in harm to the user and/or damage to the regulator and/or solar blanket. Only use the Solar Regulator for charging standard lead acid, calcium content, Gel & AGM type 12 V and 24 V batteries.
3. Over Charging Hazard. Failure to connect solar panel's negative wire directly to the regulator may result in overcharging the battery. The solar panel's negative wire must be connected directly to the regulator only.

4. Check the battery manufacturer's data for your battery and ensure that the voltage of the charging profile you select does not exceed the manufacturer's recommended maximum charging voltage. If the absorption and boost voltage for your battery type is too high, please select another charging profile. The Solar Regulator is not intended to supply power to a low voltage electrical system other than to charge a battery.
5. Electrical Hazard. Incorrect connection of batteries and solar panels in Parallel or Series can subject the regulator to high voltages that will damage the regulator. Ensure the recommended connections and sequences are followed and that the rated current, wattage or voltage of the regulator is not exceeded.
6. NEVER smoke or allow a spark or flame in vicinity of battery or engine. This may cause the battery to explode.

PERSONAL SAFETY PRECAUTIONS

7. To assist with the safe operation and use of the Solar Regulator:
 - a. Wear complete eye protection and clothing protection. Avoid touching eyes while working near a battery.
 - b. If battery acid contacts your skin or clothing, remove the affected clothing and wash the affected area of your skin immediately with soap and water. If battery acid enters your eye, immediately flood the eye with running cold water for at least 10 minutes and seek medical assistance immediately.

NOTICE

The Solar Regulator will achieve best results when proper battery maintenance is regularly performed. This includes but is not limited to checking water and specific gravity levels of the battery.

CONTENTS

THE SOLAR REGULATOR	2
WARNING & SAFETY INSTRUCTIONS	2
1 SPECIFICATIONS	3
1.1 Dimensions	3
1.2 General Specifications	4
2 THE SOLAR REGULATOR	5
2.1 Regulator Function	5
2.2 Connection	5
2.3 Indication	5
2.4 Setting Modes	6
2.5 Modes	6
3 SYSTEM SETUP	7
3.1 Fuse Protection	7
3.2 Installation Notes	7
3.3 Standard Setup (12 V)	8
3.4 Dual Battery Setup (24 V)	8
3.5 Dual battery setup with Multiple solar panels	9
3.6 Setup for a single AGM or Gel type battery	9
3.7 Setup for standard lead acid batteries, 70% charge priority to battery 1	10
3.8 Setup for calcium content batteries, 40% charge priority to battery 1	10
WARRANTY	11

1 SPECIFICATIONS

1.1 Dimensions

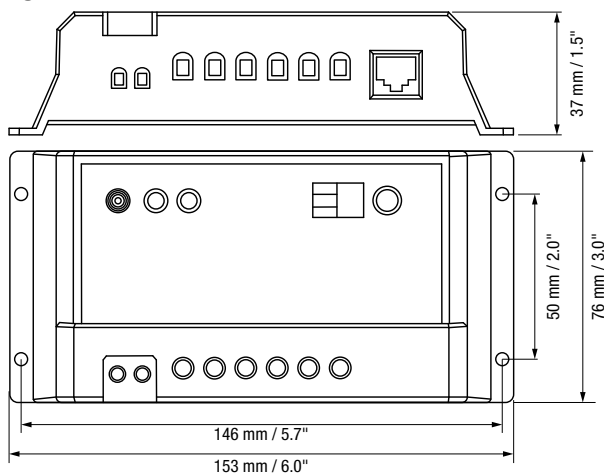

1 SPECIFICATIONS

1.2 General Specifications

System Voltage	12 V			24 V		
Battery Type	AGM/Gel	SLA	Calcium	AGM/Gel	SLA	Calcium
Absorption Voltage*	14.4 V	14.6 V	14.8 V	28.8 V	29.2 V	29.6 V
Float Voltage*	13.6 V	13.6 V	13.6 V	27.2 V	27.2 V	27.2 V
Maximum Input Voltage	30 V			55 V		
Battery Voltage Range	9 – 15 V			18 – 30 V		
Power Rating	120 W (SRP0120) / 240 W (SRP0240)			240 W (SRP0120) / 480 W (SRP0240)		
Current Limit	10 A (SRP0120) / 20 A (SRP0240)					
Absorption Time	2 hours					
Standby Current Draw	4 mA					
Nominal Current Draw	10 mA					
Remote Connection	8-pin RJ-45					
Temp. Compensation	-30 mV / °C / 12 V (-16.7 mV / °F / 12 V)					
Terminals	4 mm ² / 12 AWG					
Operating Temp.	-35°C to +50°C / -31°F to +122°F					

*Charge profile voltages will change with temperature compensation

2 THE SOLAR REGULATOR

2.1 Regulator Function

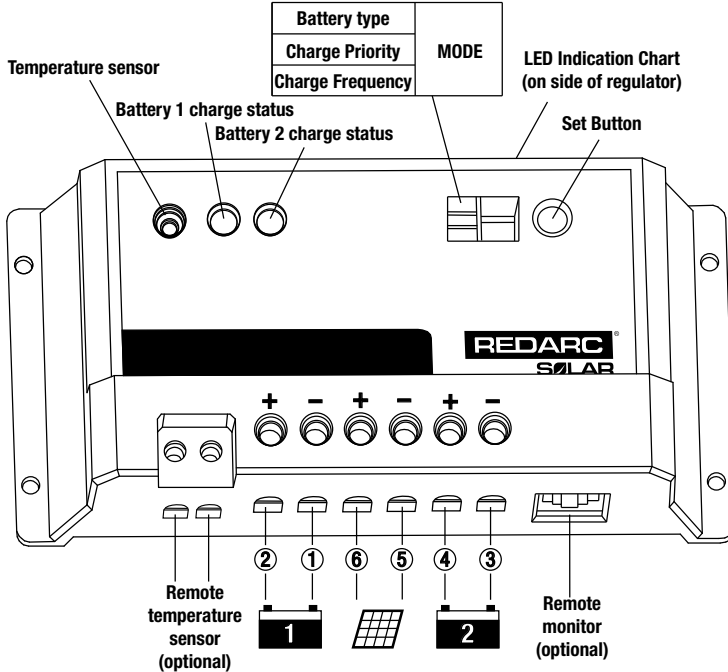

2.2 Connection

The regulator should be connected to the battery according to the diagram above. The connection order is indicated by the numbers circled.

Incorrect connection of the battery can damage the regulator.

The Remote temperature sensor is optional and the regulator will still operate without it connected.

The Remote monitor is optional and the regulator will still operate without it connected.

2.3 Indication

1. LED flash (multiple flashes per second)	Short circuit — check the Solar panel and the battery to make sure that they are connected correctly.
2. LED flash (1 flash per second)	Fully charged.
3. LED ON	Charging.
4. LED flash (1 flash every 3 seconds)	Battery connected, no charge current.
5. LED OFF	No connection or Over voltage.

2 THE SOLAR REGULATOR

2.4 Setting Modes

NOTE:

- The regulator will automatically sense the battery voltage.
 - A 24 V battery system must have 24 V solar panels and a 12 V battery system must have 12 V solar panels.
1. Press the Set button to start the mode select process.
 2. Press the Set button to cycle through to the mode required.
 - Battery Type
 - Charge Priority
 - Charge Frequency
 3. Once the correct mode is selected, press and hold the Set button for 5 seconds, until the LED and setting begin to flash, to change the setting for the selected mode.
 4. Press the Set button to cycle through the settings.
 5. Once the desired setting is selected, leave the Set button for 5 seconds to save the setting and return to the mode select process.
 6. Once all modes have been set, leave the Set button for 5 seconds and the mode select process will end.

2.5 Modes

1st LED - Battery Type	
Setting	Battery Type
1	AGM / Gel
2	Lead Acid
3	Calcium

3rd LED - Charge Frequency	
Setting	PWM Frequency
0	25 Hz (Factory set)
1	50 Hz

2nd LED - Charge Priority

Setting	Battery 1 %	Battery 2 %
0	0%	100%
1	10%	90%
2	20%	80%
3	30%	70%
4	40%	60%
5	50% (Factory set)	50%
6	60%	40%
7	70%	30%
8	80%	20%
9	90%	10%

When setting the charge priority, only Battery 1 percentage needs to be set. Battery 2 percentage is automatically calculated by the regulator.

During normal charging the regulator will divide the charging as per the settings. If Battery 1 is fully charged, more charge will go to Battery 2. If Battery 2 is disconnected all the charge current will go to Battery 1.

If MODE LED flashes 'H', the temperature exceeds 55°C / 131°F and the units temperature protection is active. The unit will restart once the temperature is within safe limits.

⚠ CAUTION

OVER CHARGING HAZARD. FAILURE TO CONNECT SOLAR PANEL'S NEGATIVE WIRE DIRECTLY TO THE REGULATOR MAY RESULT IN OVERCHARGING THE BATTERY. THE SOLAR PANEL'S NEGATIVE WIRE MUST BE CONNECTED DIRECT TO THE REGULATOR ONLY.

ELECTRICAL HAZARD. INCORRECT CONNECTION OF BATTERIES AND SOLAR PANELS IN PARALLEL OR SERIES CAN SUBJECT THE REGULATOR TO HIGH VOLTAGES THAT WILL DAMAGE THE REGULATOR. ENSURE THE RECOMMENDED CONNECTIONS AND SEQUENCES ARE FOLLOWED AND THAT THE RATED CURRENT AND/OR WATTAGE OF THE REGULATOR IS NOT EXCEEDED.

3.1 Fuse Protection

Fuse protection is required for wire and component protection in case of short circuit. Fuses are to be fitted as close as possible to the battery positive terminal.

REDARC recommend using MIDI style bolt down fuses as they ensure a low resistance connection.

The REDARC FK40 and FK60 fuse kits are recommended.

Blade type fuses are not recommended as they can result in high resistance connection which causes excess heat and may damage the fuse holder and/or the wiring. Self-resetting circuit breakers are not recommended as they may trip prematurely due to the heat generated by the current flowing through the wires.

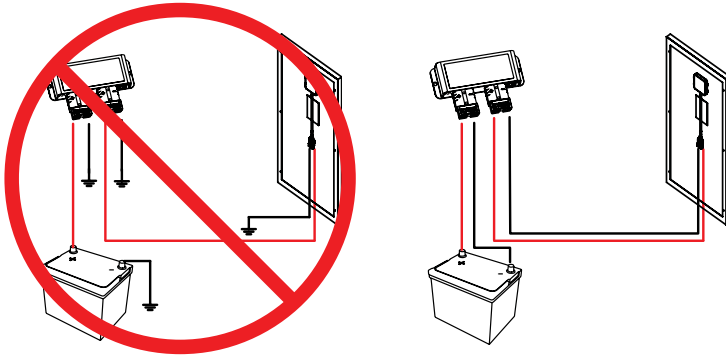

3.2 Installation Notes

- Always connect the battery/s first (before the panel).
- Always ensure the connection to the battery terminals is sound, with as much surface contact between the battery terminal and the connection method (e.g. alligator clips) as possible.
- The regulator should be installed as close as possible to the battery/s.
- If 2 batteries are installed, they must be of the same chemistry ie. both of Calcium content.
- It is recommended to ensure non-REDARC panels have suitable bypass diodes installed.
- Always check the manufacturers data for your battery and ensure that the maximum voltage of the battery type you select does not exceed the manufacturers recommended maximum charging voltage. If the maximum voltage for your battery type is too high, please select another battery profile.

3 SYSTEM SETUP

3.3 Standard Setup (12 V)

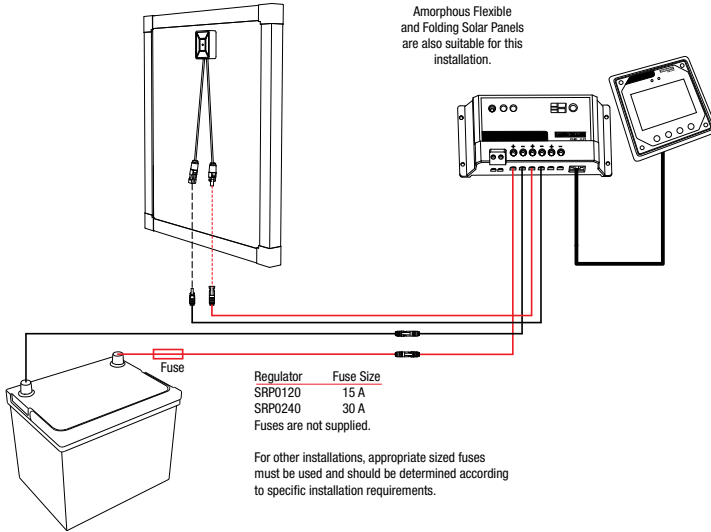

3.4 Dual Battery Setup (24 V)

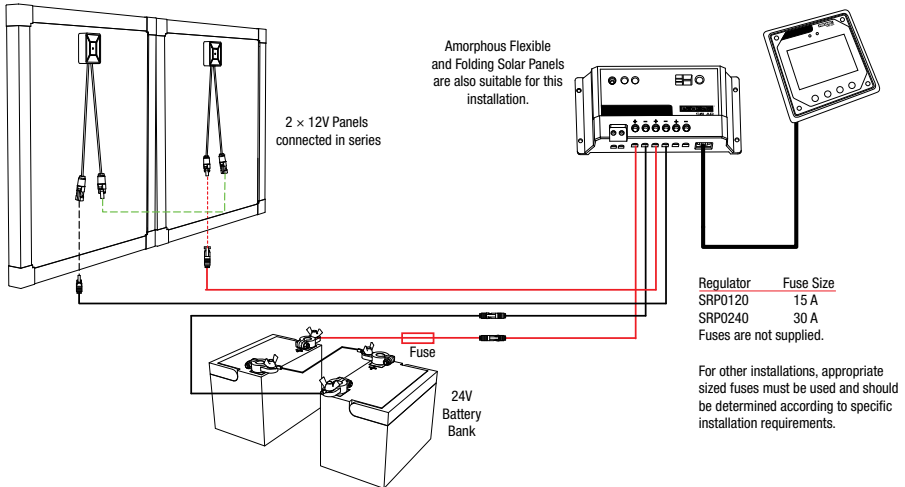

NOTICE

- Both panels used must be identical, mixing and matching may cause damage. The lowest rated current panel will dissipate heat if they are not matched.
- Both panels must be positioned next to each other at the same angle to enable identical lighting conditions otherwise damage can be caused and/or batteries may not charge.

3 SYSTEM SETUP

3.5 Dual battery setup with Multiple solar panels

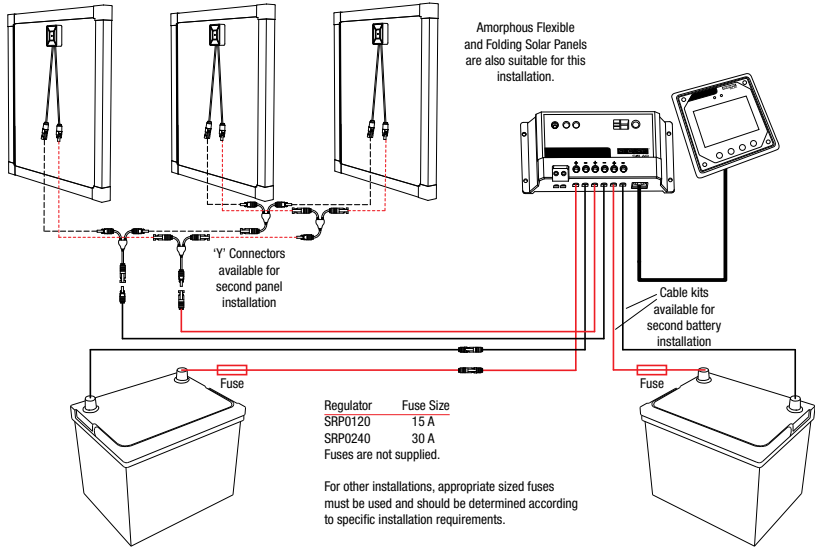

3.6 Setup for a single AGM or Gel type battery

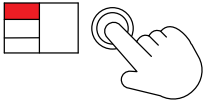

Press the 'Set' button and cycle until the first LED is on (Battery Type).

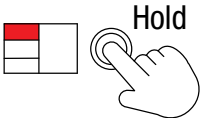

Hold

Press and hold the 'Set' button for 5 seconds to enter the setting change state for mode Battery Type.

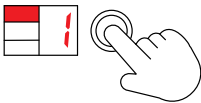

Press the 'Set' button until the number '1' appears as the setting value. (Set for AGM or Gel)

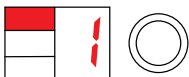

Leave the 'Set' button for 5 seconds to save the setting.



Leave the 'Set' button for 5 seconds to exit mode select.

The Charge Priority does not need to be set for a 1 battery setup as under these circumstances the battery that is connected will receive 100% of the charge.

NOTE: Charge frequency is set to 25 Hz as a factory setting. It is not recommended to change this setting unless absolutely necessary. If you are unsure as to what this setting should be, please leave as 25 Hz.

3.7 Setup for standard lead acid batteries, 70% charge priority to battery 1

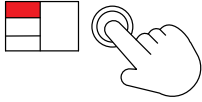

Press the 'Set' button and cycle until the first LED is on (Battery Type).

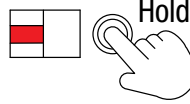

Press and hold the 'Set' button for 5 seconds to enter the setting change state for mode Charge Priority.

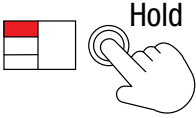

Press and hold the 'Set' button for 5 seconds to enter the setting change state for mode Battery Type.

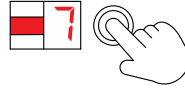

Press the 'Set' button until the number '7' appears as the setting value.



Press the 'Set' button until the number '2' appears as the setting value. (Set for Std. Lead Acid)

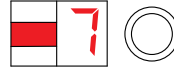

Leave the 'Set' button for 5 seconds to save the setting.



Leave the 'Set' button for 5 seconds to save the setting.

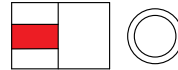

Leave the 'Set' button for 5 seconds to exit mode select.

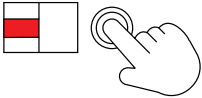

Press the 'Set' button and cycle until the second LED is on (Charge Priority).

3.8 Setup for calcium content batteries, 40% charge priority to battery 1

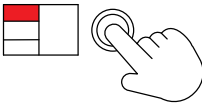

Press the 'Set' button and cycle until the first LED is on (Battery Type).

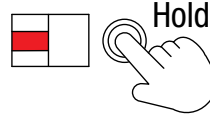

Press and hold the 'Set' button for 5 seconds to enter the setting change state for mode Charge Priority.

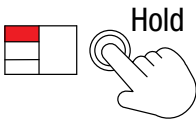

Press and hold the 'Set' button for 5 seconds to enter the setting change state for mode Battery Type.

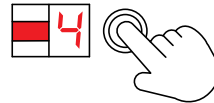

Press the 'Set' button until the number '4' appears as the setting value.

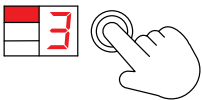

Press the 'Set' button until the number '3' appears as the setting value. (Set for Calcium Content)

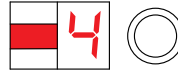

Leave the 'Set' button for 5 seconds to save the setting.



Leave the 'Set' button for 5 seconds to save the setting.

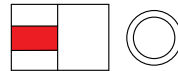

Leave the 'Set' button for 5 seconds to exit mode select.

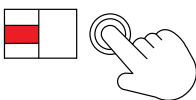

Press the 'Set' button and cycle until the second LED is on (Charge Priority).

WARRANTY

Limited Warranty

For full warranty terms and conditions, visit the link below or refer to the contact details applicable to your region.

Australia and New Zealand

www.redarc.com.au/warranty

REDARC Electronics Pty Ltd
23 Brodie Road (North),
Lonsdale SA 5160
Australia

North America

www.redarcelectronics.com/warranty

REDARC Corporation
c/o Shallco, Inc.
308 Component Dr.
Smithfield, NC 27577
USA

Australia 1300 REDARC (1300 733 272)
New Zealand +64 9 222 1024
UK/Europe +44 (0)20 3930 8109

USA +1 (704) 247 5150
Canada +1 (604) 260 5512
Mexico +52 (558) 526 2898

THE POWER OF

REDARC®

SOLAR

Australia

power@redarc.com.au
www.redarc.com.au
+ 1300 REDARC (1300 733 272)

New Zealand

power@redarcelectronics.co.nz
www.redarcelectronics.co.nz
+64 9 222 1024

North America

power@redarcelectronics.com
www.redarcelectronics.com

United States

+1 (704) 247 5150

Canada

+1 (604) 260 5512

Mexico

+52 (558) 526 2898

UK/Europe

power@redarcelectronics.eu
www.redarcelectronics.eu
+44 (0)20 3930 8109

www.redarc.com.au