



OFFTRACK NUDGE BAR

FITTING INSTRUCTIONS



MITSUBISHI PAJERO SPORT 2016 ON

PK101MPS16

Fitting Time : approx. 1.5-2 hours



BULL BAR SAFETY NOTICE:

INSTALLATION SHOULD ONLY BE DONE BY APPROPRIATELY QUALIFIED OR EXPERIENCED PERSONS IN ACCORDANCE WITH THESE INSTRUCTIONS.

IT IS THE RESPONSIBILITY OF THE INSTALLER TO ENSURE THAT THE PRODUCT IS CORRECTLY FITTED.

WARNING:

Do not attach Vehicle Frontal Protection System (**VFPS**) to the vehicle using anchorages not intended for this purpose. (e.g. engine mounting bolts)

Do not use this product for any vehicle make or model, other than those specified by the VFPS manufacturer.

Do not remove the plaque or label from the VFPS.

Do not modify the structure of the VFPS in any way.

The VFPS has been produced to provide continued functionality of parking sensors and other "driver assist" features as closely as possible to Original Equipment. However, as all possible road conditions and combination of other accessories fitted to the vehicle which may affect functionality characteristics cannot be anticipated, ***the driver remains responsible at all times for properly controlling the vehicle, monitoring all "driver assist" features and intervening where required to ensure the vehicle is safely operated.***

IMPORTANT INFORMATION:

Before installing the VFPS:

Check that all components, as listed in the assembly table, are available.

Thoroughly read all instructions.

This product or its fasteners must not be modified in any way.

These instructions are accurate as at the revision date and do not take into account any changes made by the vehicle manufacturer to vehicle design after the revision date or other accessories that are or have been fitted to the vehicle. PIAK cannot be held responsible for such changes and appropriate enquiries should be made before installation.

Before installing, inspecting and/or maintaining the VFPS, the work space should be safe and clear of fuel, debris, electrical or other components.

During installation:

It is the responsibility of the installer to confirm correct operation/clearance of all components.

All holes drilled shall have all burrs and swarf removed then coated with a suitable rust preventative paint.

Ensure that all hardware is fastened to torque list as detailed in these instructions.



MAINTENANCE AND CARE:

To ensure continued safety and correct operation of the product, the VFPS must be routinely inspected and regularly serviced (including bolt torque checked for correct tension) by an appropriately qualified or experienced person.

The high tensile fasteners supplied with this product were used to achieve the specified rating. If replacement of the fasteners is required, fasteners of the same rating and quality must be used.

If this VFPS is fitted with a hinged number plate bracket, extra care must be taken when returning back to public roads following the use of the winch or conducting a deep water crossing.

The driver must ensure that the number plate bracket is returned back to the down position allowing full visibility of the number plate when returning to public roads.

EQUIPMENT:

These safety products should, at a minimum, be used when fitting or working on the product.



Protective Glasses



Hearing Protection

Installation in accordance with these instructions and adherence to warnings will ensure compliance with relevant regulatory and safety standards as at the revision date.

Failure to adhere to these instructions may affect the roadworthiness of the vehicle or cause personal injury, death or damage to property.

BY USING THIS PRODUCT YOU ACKNOWLEDGE AND AGREE THAT TO THE EXTENT PERMITTED BY LAW PIAK WILL NOT ACCEPT LEGAL OR OTHER LIABILITY FOR ANY LOSS, INJURY OR DAMAGE CAUSED BY INCORRECT OR INAPPROPRIATE INSTALLATION OR USE OF THE PRODUCT.

License Plate Bracket MPS16			
Item	Component Name	Q'ty	Remarks
13	Hex bolt M6x1.0xL20	6	
14	Flange nut M6x1.0	6	
15	M6 Flat washer OD14	6	
16	M6 Spring washer	6	
17	SENSOR BLANKING PLUG_Dia 28mm	2	
18	Button head M4x0.7xL12	2	
19	Hex nut M4x0.7	2	
20	Cable tie 150 mm.	10	

Components Overview

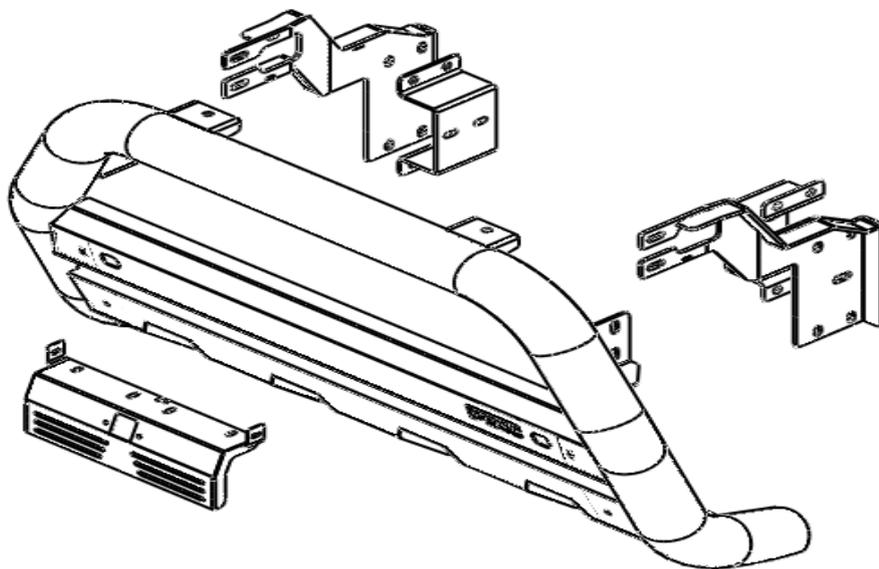

TORQUE SETTING OF FASTENER

Mounting bolts must be tightened to torque's specified following ;

Bolt Diameter (mm.)	Torque (Nm)	Torque (ft.lb)
M6	9	7
M8	22	16
M10	44	32
M12	77	57

FITTING PROCEDURE



- 1 Locate the vehicle in a suitable position. Rest the bullbar on a surface that will not scratch the bar.



- 2 Remove the clips that retain the grille at the top. Keep for re-fitment of grille.



- 3 Unclip and remove the grille from vehicle and place on a soft surface

Notice- Refer to vehicle repair manual for correct removal procedure.



- 4 Unclip the wiring looms coming from behind the bumper bar.

Remove and retain the camera carefully.
Bracket from grille Making sure that it will not damage Processors.

FITTING PROCEDURE



- 5** Remove the fog light surrounds from the bumper.



- 6** Remove hex nut M6 (one either side) retaining the lower bumper.

Repeat in step 5-6 for the opposite side.

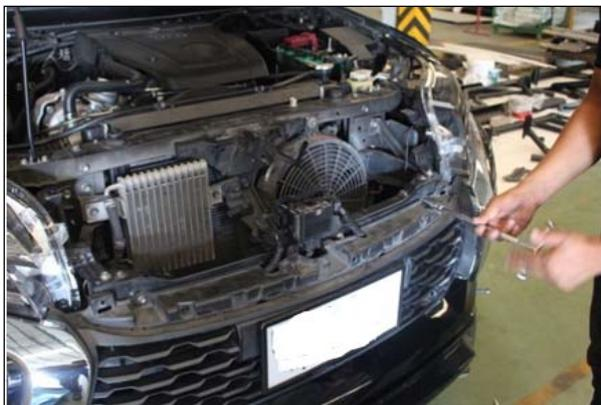

- 7** Remove and retain the three M6 bolts retaining the top of the bumper.



- 8** Remove and retain the screws retaining the bumper bar in the wheel arch.

Repeat the opposite side.

FITTING PROCEDURE



- 9** Unlocked carefully pulled bumper removal.

Repeat for the opposite side.



- 10** Carefully remove the bumper from the vehicle.

If unsure about bumper removal refer to the workshop manual.



- 11** Unlock water pipe Headlight Washer Water .



- 12** Drain the fluid from the washer bottle.

If fitting to a GLX or GLS model vehicle remove the washer bottle.

FITTING PROCEDURE



- 13** Unlock sensor plug and move sensor head to put into Nudge bar correct orientation same with original bumper and spread out the wire from vehicle to get more long wire sensor and wire through the hole of the grille as shown.

****Note ****Replace by sensor plugs supplied



- 14** Unlock spread out the wire from vehicle to get more long wire camera.

Run the camera wiring through the hole.

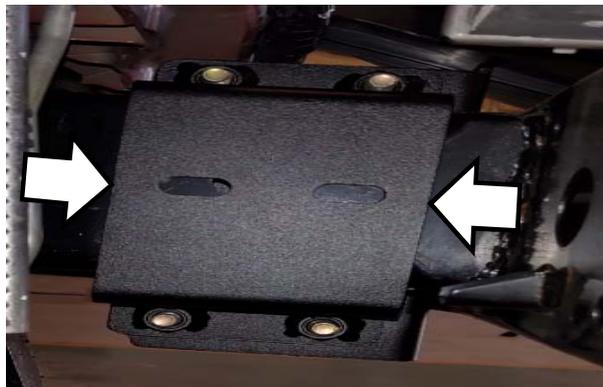

- 15** Place the inner brackets (item 2) over the inside of the chassis rails.

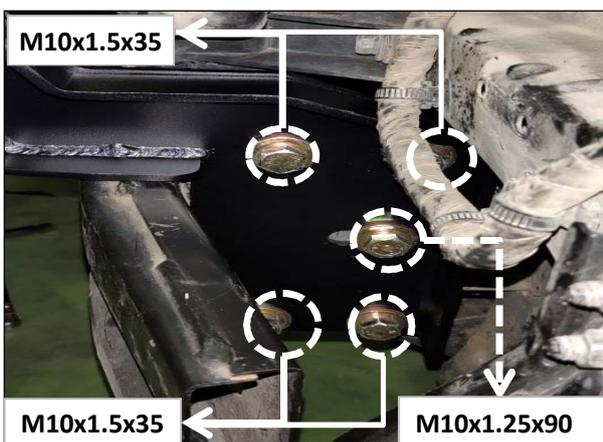

- 16** Using four M10 x 1.5 x 35 hex bolts, M10 x 1.25 x 90 hex bolts, M10 spring and flat washers loosely fit the chassis mount bracket (item 3).

FITTING PROCEDURE



- 17** Repeat steps 13 to 14 for the opposite side.



- 18** Re-install the front bumper and place the chassis mounting bracket through out the bumper as shown.

Ensure the Parking sensors hang freely below the grille for easy access during A-bar fitment.



- 19** Fit the parking sensor into the sensor housing.

- 20** Repeat for the opposite side



- 21** Place sensors in the nudge bar bracket, Carefully locate the sensors and bracket into the bar correct orientation same with original in bumper.

FITTING PROCEDURE



- 22** Fit the front camera to the License Plate Bracket as shown by Button head M4x0.7x12 and hex nut M4.



- 23** Lift the A- bar fit to the chassis mount ,Align the A- Bar to the desired position, and fully tighten the Chassis Mounting Bolts. by using four M10 Socket head (M10x40x1.5), spring washers, flat washers and M10 flange nut

Repeat for the opposite side. and fully tighten.



- 24** Align the A- Bar to the desired position and Reconnect Parking sensors on either side of the front bar .



- 25** Assemble License plate bracket by using M6 x L 20, M6 Flat washer , M6 Spring washer , Flange nut M6 and fully tighten.

FITTING PROCEDURE



- 26 Adjust the front camera onto the car so that it is centered .



- 27 Reconnect the front camera.



- 28 Re-install the grille and engine bay top cover with original fasteners.



- 29 Check Parking Sensor Compatibility. Now that Nudge Bar is centred, ensure that it is not interfering with the front parking sensors. You may need to adjust the sensor housing if you have any issues.

NOTE : The parking sensors are very sensitive and if the sensor is off-centre by even a few mms, it can cause the sensors to pick up the bar. If you're having trouble, be sure the Parking sensor are installed correctly.

FITTING PROCEDURE

PIAK NUDDGE BAR NOW FULLY INSTALLED



FASTENERS • Check fastener tightness regularly and tighten if required. We recommend checking fasteners after every large off-road trip.